



ACCESSORIES & ANCILLIARIES

Mechanical Parts & Spares





CONTENTS

PAGE

Tube & Box Fans

4

High Temperature Roof Fans

12

Standard Temperature Roof Fans

13

Plate Fans

15

Cased Axial Fans

16

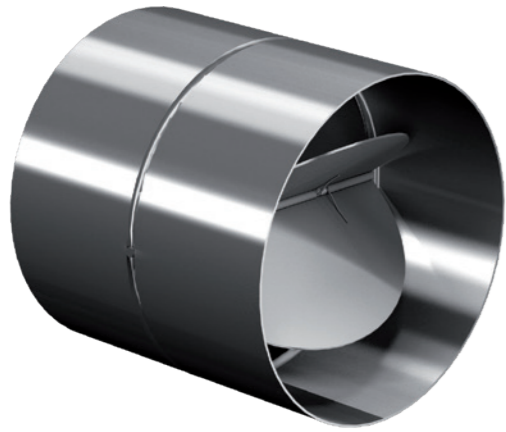

BDS - Back Draught Damper

Automatic back draught damper with flute mechanism for installation into the tube system. Opening in air stream, closing via flute power. Casing made of galvanised sheet steel with aluminium back draught damper.

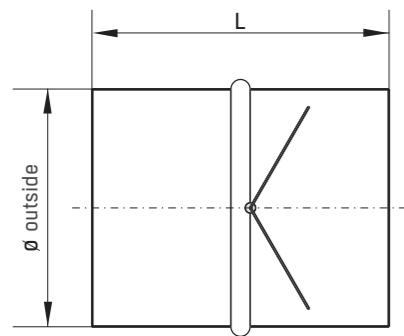

Product Code	Product Number	Ø Outside	L
100	BS100000	100	96
125	BS125000	125	96
150	BS150000	150	96
160	BS160000	160	96
200	BS200000	200	113
250	BS250000	250	113
315	BS315000	315	113
355	BS355000	355	113
400	BS400000	400	113
710	BS710000	710	250
800	BS800000	800	340



CFC - Duct Clamps

Clamps made of galvanised sheet steel, for a low-noise connection between fan and duct. Inside lined with foam.

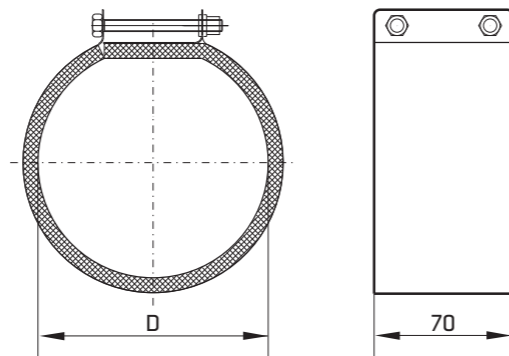

Size	Product Number	ØD
100	CP100000	100
125	CP125000	125
150	CP150000	150
160	CP160000	160
200	CP200000	200
250	CP250000	250
315	CP315000	315
355	CP355000	355
400	CP400000	400



SFC - Flexible Connection

ePowerbox SFC flexible connector flanges are made of galvanised sheet steel, while the flexible middle section is manufactured from PVC woven cloth which has a maximum temperature rating of up to +70°C.

Estoc Targe flexible connector flanges are made of galvanised sheet steel, while the flexible middle section is manufactured from PU coated fibre glass cloth which has a maximum temperature rating up to +180°C.

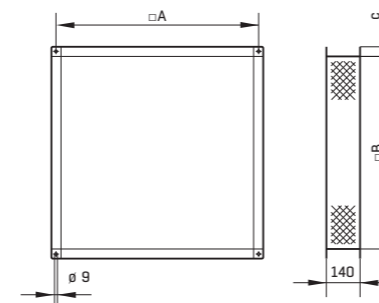

Size	Product Number	a	b	c
ePowerBox 50-355	BI101030	433	409	20
ePowerBox 67-400	BI101031	603	579	20
ePowerBox 67-500	BI101031	603	579	20
ePowerBox 67-560	BI101033	697	659	30
ePowerBox 67-630	BI101033	697	659	30
ePowerBox 102-710	BI101035	917	879	30
Estoc Targe 50-355 - Outlet	BI101073	398	218	30
Estoc Targe 50-355 - Inlet	BI101074	388	388	30
Estoc Targe 67-400+450 - Outlet	BI101075	568	258	30
Estoc Targe 67-400+450 - Inlet	BI101076	488	488	30
Estoc Targe 80-500+630 - Outlet	BI101077	698	338	30
Estoc Targe 80-500+630 - Inlet	BI101078	618	618	30
Estoc Targe 102-630 - Outlet	BI101079	918	398	30
Estoc Targe 102-630 - Inlet	BI101080	788	788	30

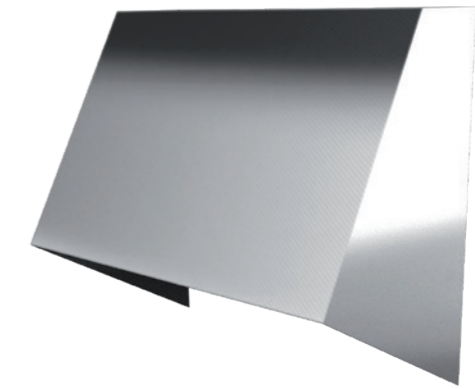

SOC - Outlet Cover

Weather protection outlet cover is manufactured from galvanised sheet steel and is designed for products that discharge air directly to atmosphere.

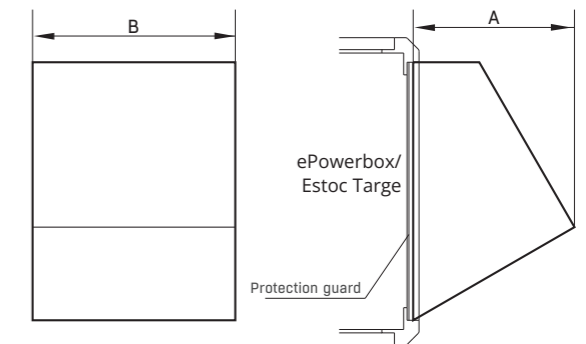

Size	Product Number	a	b	c
ePowerbox 50-355	BI101054	300	450	1.6
ePowerbox 67-400/500	BI101055	380	620	2.8
ePowerbox 80-560/630	BI101057	430	720	3.9
ePowerbox 102-710	BI101059	520	940	5.2
Estoc Targe 50-355	BI101107	300	340	1.4
Estoc Targe 67-400/450	BI101108	380	420	3.2
Estoc Targe 80-500/560/630	BI101110	430	510	3.9
Estoc Targe 102-630	BI101113	520	800	4.8

All dimensions shown in mm

All dimensions shown in mm



MF - Mounting Foot (Metal)

The MF mounting foot is manufactured from galvanised steel and is designed for use with our Ropera tube fan. Fixing holes in the mounting foot tabs can be aligned to those of the fan.

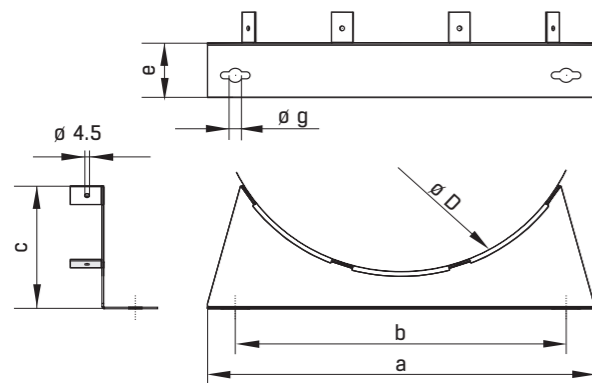

Size	Product Number	a	b	c	ØD	e	f	Øg
100-125L	MF100125	260	230	72.5	234	30	53.5	9
150-250L	MF150250	348	298	114	330	50	78.5	9
315/315L	MF315000	398	348	123	394	70	98.5	13
355/355L	MF355000	480	430	145	486	100	148.5	13



MB - Mounting Foot (Plastic)

The MB mounting bracket is manufactured from galvanised steel and is designed for use with our Espada tube fan. Fixing holes in the mounting foot are designed to allow easy fixing of the bracket to the fan body.

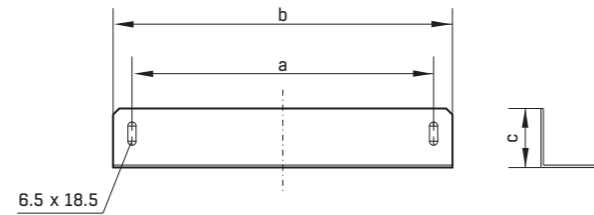

Product Code	Product Number	a	b	c
100-125L	MF100125	240	270	47
150-250L	MF150250	240	270	47
315/315L	MF315000	375	405	47



CIG - Protection Guard

Our inlet protection guard is manufactured from spiral wound steel rod and is designed to be mounted on the suction side of the fan.

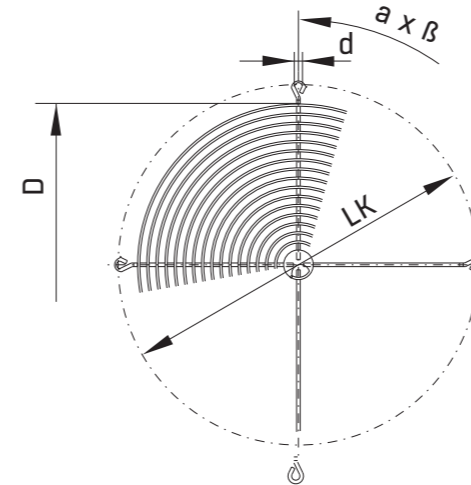

Size	Product Number	ØD
100	IG100000	100
125	IG125000	125
150	IG150000	150
160	IG160000	160
200	IG200000	200
250	IG250000	250
315	IG315000	315
355	IG355000	355
400	IG400000	400



FLS - Square Plastic Back Draught Shutter

Automatic, square plastic shutter made of plastic for high-pressure wall installation. Ex version made of conductive plastic. (Ropera and Espada only).

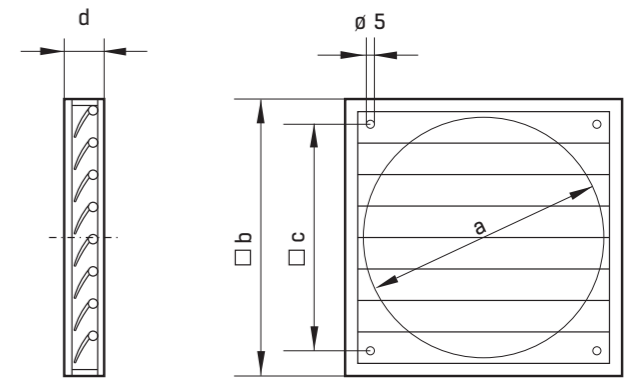

Product Code	Product Number	Ø Outside	L
100	BI100411	100	96
125	BI100347	125	96
150	BI100348	150	96
160	BI100349	160	96
200	BI100350	200	113
250	BI100351	250	113
315	BI100352	315	113
355	BI100353	355	113

All dimensions shown in mm

All dimensions shown in mm

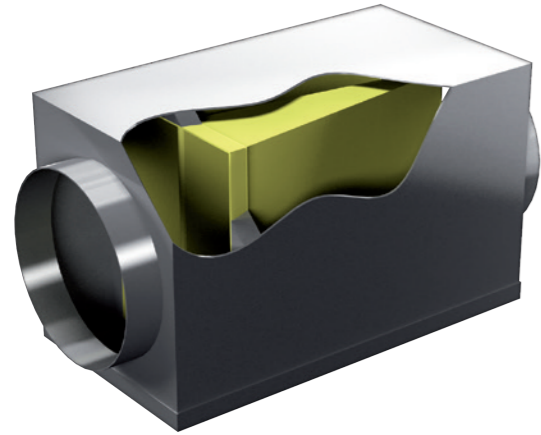

CFB - Filter Box Incl. Filter

Casing made of galvanised sheet steel with folding cover for easy filter change. Filter of filter class F5 are inclusive. Connections suitable to standard tube diameters.

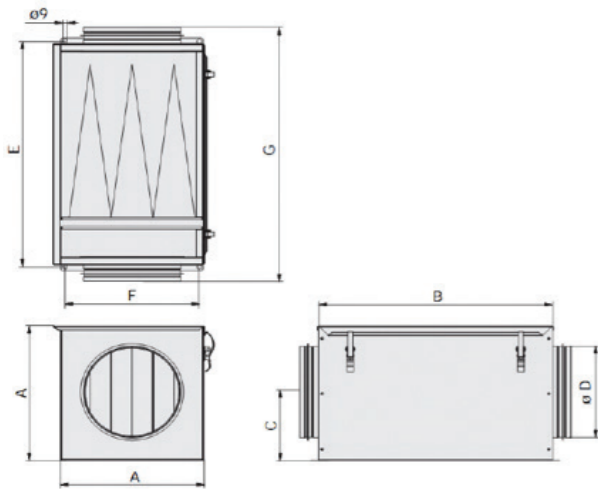

Product Number	Size	A	B	ØD	G	Weight kg
BI100354	100	200	464	100	526	2.1
BI100355	125	200	464	125	526	2.1
BI100357	160	200	464	160	526	2.1
BI100358	200	295	494	200	556	4.1
BI100359	250	295	494	250	556	4.1
BI100360	315	450	594	315	656	7.3
BI100361	355	450	594	350	656	8.1
BI100362	400	450	594	400	656	8.1

All dimensions shown in mm



SMT - Mounting Tracks

For quick and easy assembly. One delivery set contains two pieces.

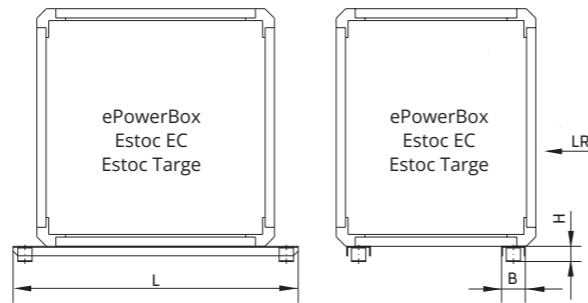

Size	Product Number	L	B	H
Estoc Targe/ePowerBox 50-355	BI101135	600	50	32
Estoc Targe/ePowerBox 67-400	BI101136	770	50	32
Estoc Targe/ePowerBox 67-450	BI101136	770	50	32
Estoc Targe/ePowerBox 80-500	BI101136	900	60	52.5
Estoc Targe/ePowerBox 80-560	BI101138	900	60	52.5
Estoc Targe/ePowerBox 80-630	BI101138	900	60	52.5
Estoc Targe/ePowerBox 102-630	BI101141	1120	60	52.5



STP - Transformation Piece (Estoc Targe Only)

Allows seamless intersection on outlet side on a standard diameter, made of galvanised sheet steel.

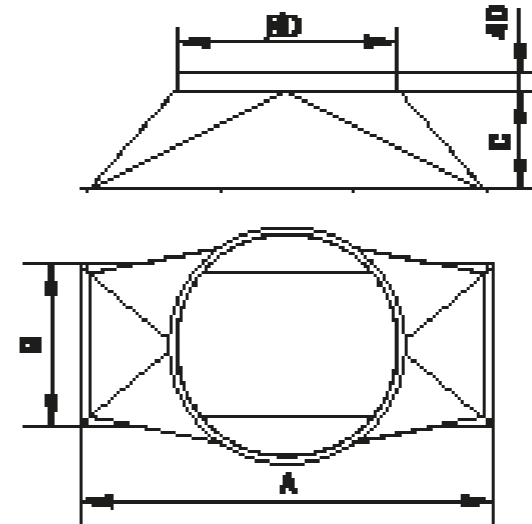

Size	Product Number	a	b	c	ØD	Hole
Estoc Targe 50-355	BI101114	418	238	250	355	4
Estoc Targe 67-400	BI101115	588	278	280	450	6
Estoc Targe 67-450	BI101115	588	278	280	450	6
Estoc Targe 80-500	BI101117	718	358	320	560	6
Estoc Targe 80-560	BI101117	718	358	320	560	6
Estoc Targe 80-630	BI101117	718	358	320	560	6
Estoc Targe 102-630	BI101120	938	418	400	630	8

All dimensions shown in mm

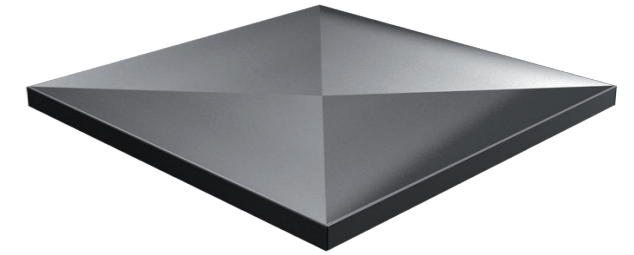

SWR - Weather Protection Roof/Cowl

Additional protection when mounted outside made of corrosion-resistant aluminium.

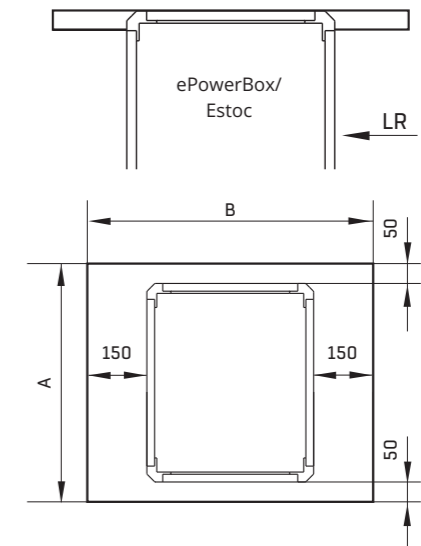

Product Code	Product Number	A	B
ePowerBox 50-355	BI101060	600	800
ePowerBox 67-400	BI101061	770	970
ePowerBox 67-450	BI101061	770	970
ePowerBox 67-500	BI101061	770	970
ePowerBox 80-560	BI101063	900	1100
ePowerBox 80-630	BI101063	900	1100
ePowerBox 102-710	BI101065	1120	1320
Estoc Targe 50-355	BI101121	600	720
Estoc Targe 67-400	BI101122	770	800
Estoc Targe 67-450	BI101122	770	800
Estoc Targe 67-500	BI101124	770	890
Estoc Targe 80-560	BI101125	900	1040
Estoc Targe 80-630	BI101126	900	1100
Estoc Targe 102-710	BI101127	1120	1180

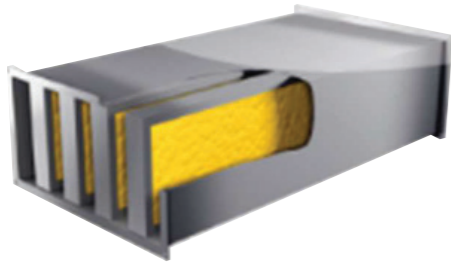

RSA - Duct Sound Attenuator

Duct sound attenuator with frame made of galvanised sheet steel. Sound trap with incombustible mineral wool according to DIN 4102 class A, Ex version with perforated steel. This guarantees a high sound insulation and due to aerodynamic optimised guide plates lower pressure losses. Max. air speed 20 m/s, max. temperature 100°C, max. pressure from -800 to 1000 Pa.

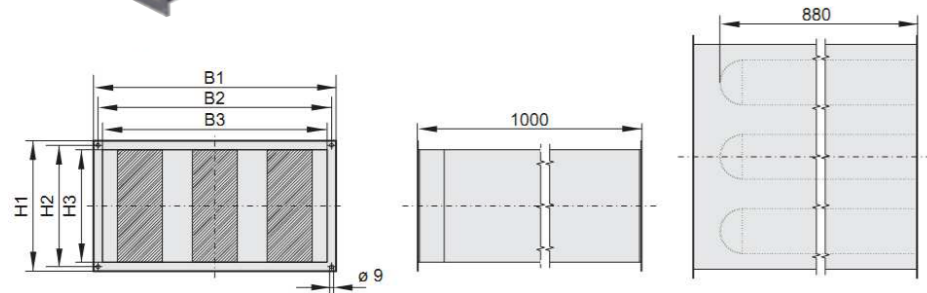

Duct Size in cm	Product Number	B1	B2	B3	H1	H2	H3	No. of sound traps	Attenuation values in dB							
									125 Hz	250 Hz	500 Hz	1k Hz	2k Hz	4k Hz	8k Hz	
Katana 315, 355, 400	BI101204	640	620	600	390	370	350	3	8	10	24	32	33	18	18	
Katana 450	BI101205	740	720	700	440	420	400	3	5	8	17	23	28	17	17	
Katana 500	BI101206	840	820	800	540	520	500	3	5	8	19	27	27	15	15	
Katana 560	BI101207	1040	1020	1000	540	520	500	4	4	10	12	18	19	12	12	



RFC - Flexible Duct Connection

Flexible duct connection with flange frame made of galvanised sheet steel. Flexible middle section made from PVC woven cloth with a temperature range of up to +70°C. Electroconductive and therefore also suitable for explosion proof fans.

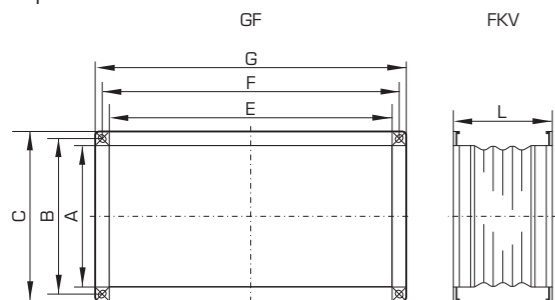

RFC - Duct Connection Flange

Harmonised flange made of galvanised sheet steel for temperatures of up to +120°C, suited for ex-applications.

Product Size	Product Number Flexible	Product Number Flange	A	B	C	E	F	G	L min
Katana 315, 355, 400	BI100367	BI100377	350	370	390	600	620	640	140
Katana 450	BI100368	BI100378	400	420	440	700	720	740	140
Katana 500	BI100369	BI100379	500	520	540	800	820	840	140
Katana 560	BI100372	BI1003828	500	520	540	1000	1020	1040	140

All dimensions shown in mm



RLS - Plastic Shutter

Automatic, rectangular plastic shutter made of plastic for high-pressure wall installation.

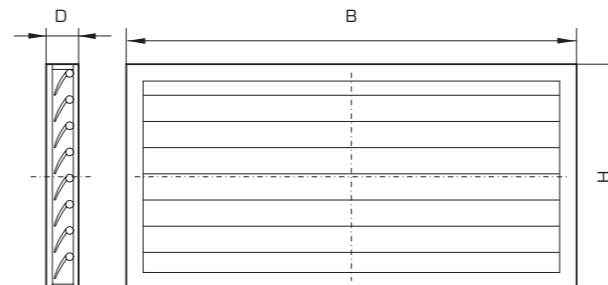

Product Size	Product Number	B	H	D	Weight kg
200	BI100383	398	198	40	0.5
225	BI100384	498	248	40	0.5
250	BI100385	498	298	40	1.0
280	BI100387	598	298	40	1.0
315	BI100388	598	348	40	1.0
355	BI100389	698	398	40	1.5
400	BI100390	798	498	40	2.0
450	BI100391	898	498	40	2.0
560	BI100392	998	498	40	2.25

Product Code	Product Number	B	H
Katana 315, 355, 400	BI100406	600	350
Katana 450	BI100407	700	400
Katana 500	BI100408	800	500
Katana 560	BI100410	1000	500

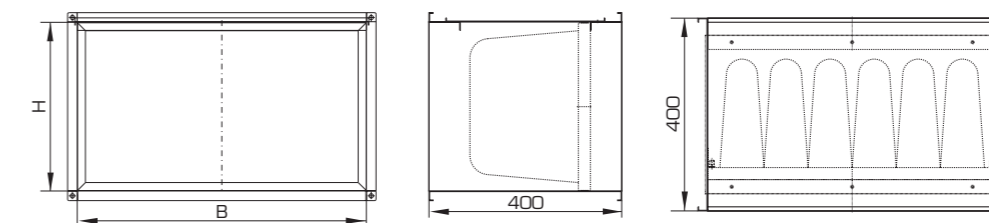

RFB - Filter Box Incl. Filter

Casing made of galvanised sheet steel with folding cover for an easier filter change. Pocket filter of filter class (F7 as optional). Connections on rectangular duct system.

All dimensions shown in mm



RAD - Air Damper

For mounting into duct systems. Casing made of galvanised sheet steel, lamellas made of aluminium. Exterior adjusting lever for regulating mechanism of lamellas.

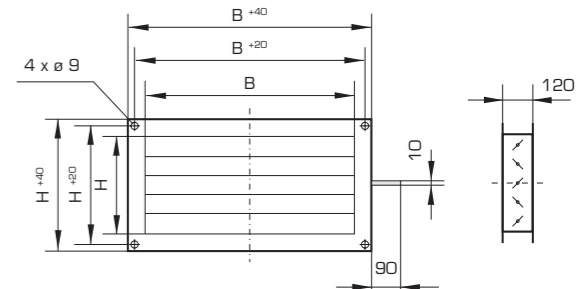

Product Code	Product Number	b	c
Katana 315, 355, 400	BI100398	600	350
Katana 450	BI100399	700	400
Katana 500	BI100400	800	500
Katana 560	BI100401	1000	500

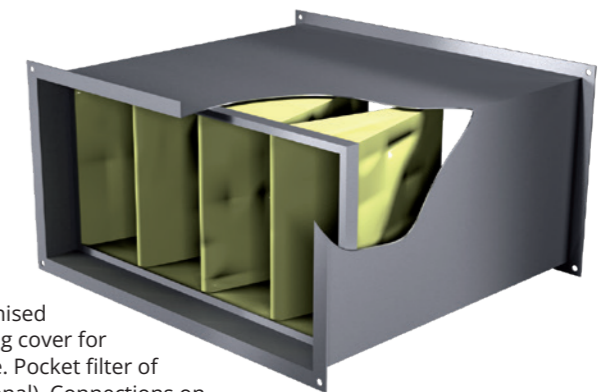

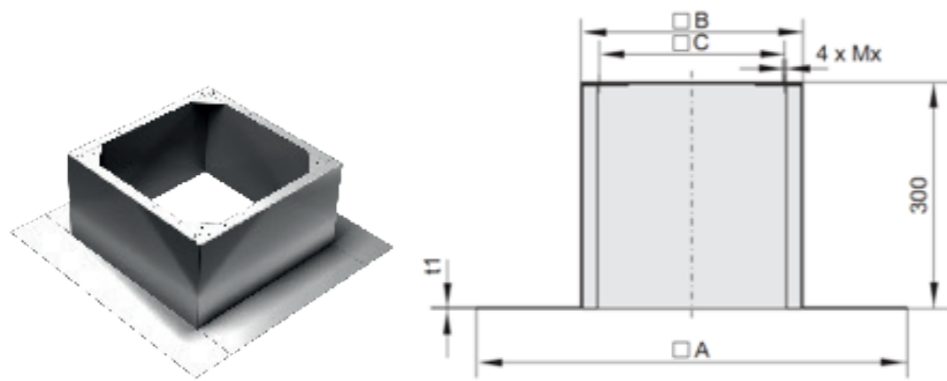

Flat Roof Socket

Size	Part Number	A	B	C	Mx	t1	Weight kg
190/225	FS019000	571	294	245	M6	2.0	3.5
280/310	FS031000	657	395	330	M6	2.0	4.5
355/400	FS035500	817	555	450	M10	2.0	6.5
455/500	FS045000	877	625	535	M10	2.0	7.0
560/630	FS056000	1200	895	750	M10	2.0	10.0
710	FS071000	1300	985	840	M10	2.0	12.0
800/900	FS080000	1490	1205	1050	M12	4.0	15.0

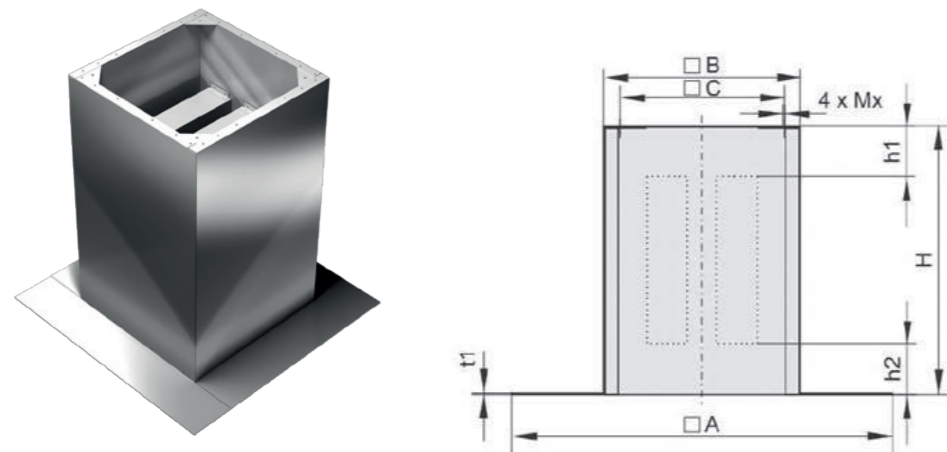

Socket Sound Attenuator

Size	Part Number	A	B	C	H	Mx	t1	h1	h2	Weight kg
190/225	SD019021	571	294	245	600	M6	2	150	150	9
280/310	SD031021	710	395	330	700	M6	2	180	150	16
355/400	SD035521	874	555	450	900	M10	2	250	200	24
450/500	SD045021	900	625	535	900	M10	2	270	250	26
560/630	SD056021	1200	895	750	1070	M10	2	320	320	39
700	SD071018	1300	985	840	1160	M10	2	300	360	45
800/900	SD080000	1740	1205	1050	1230	M12	4	405	125	154

All dimensions shown in mm

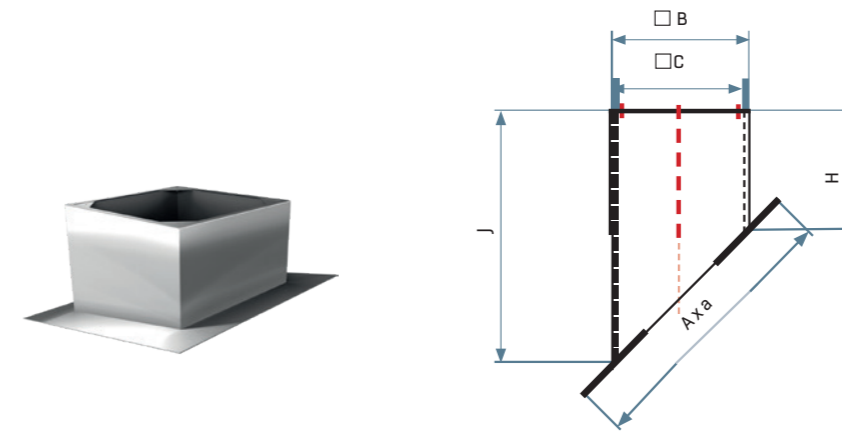

Base for Sloping Roof (5-45°)

Size	Part Number	A	a	B	C	H	J	Weight kg
190/225	FS019050	X	571	294	245	300	X	3.5-5.5
280/310	FS031050	X	657	395	330	300	X	4.5-6.5
355/400	FS035550	X	817	555	450	300	X	6.5-8.5
450/500	FS045050	X	877	625	535	300	X	7.0-10.0
560/630	FS056050	X	1200	895	750	300	X	10.0-13.0
700	FS071050	X	1300	985	840	300	X	12.0-15.0
800/900	FS080050	X	1490	1205	1050	300	X	15.0-18.0

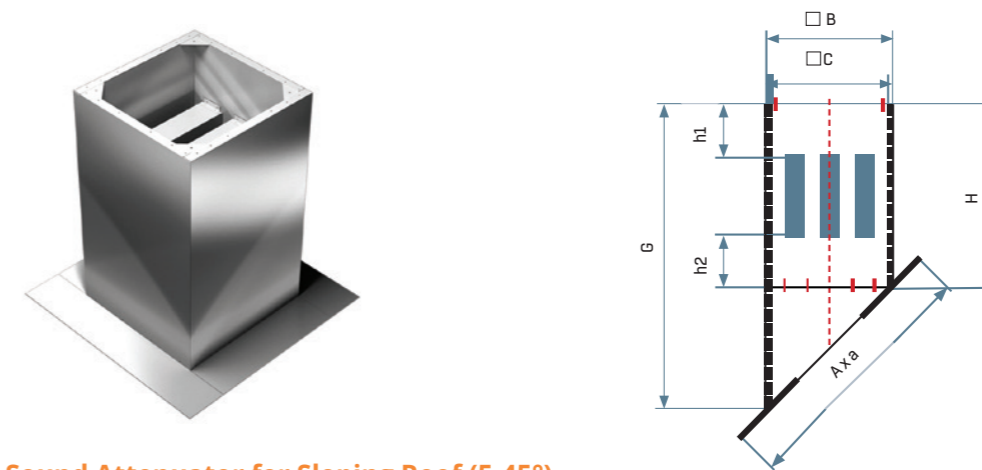

Sound Attenuator for Sloping Roof (5-45°)

Size	Part Number	A	B	C	H	Mx	t1	h1	h2	Weight kg
355/400	SD035550	X	874	555	450	900	X	250	200	33-36
450/500	SD045050	X	900	625	535	900	X	270	250	37-40
560/630	SD056050	X	1200	895	750	1070	X	320	320	52-56
700	SD071050	X	1300	985	840	1160	X	300	360	72-77
800/900	SD080050	X	1740	1205	1050	1230	X	405	125	180-195

All dimensions shown in mm

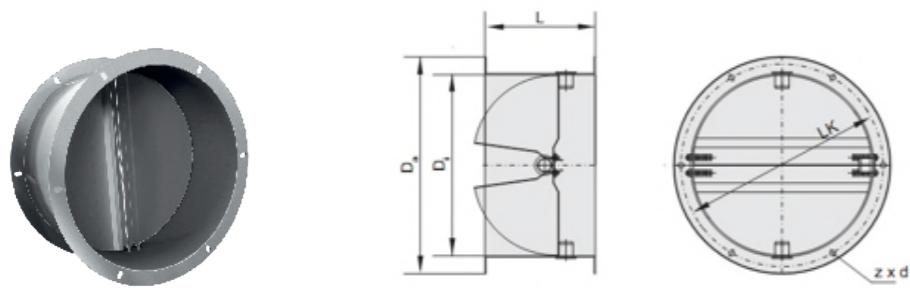

Shutters

Size	Part Number	Da	LK	DI	L	z x d	Weight kg
190/225	VS019000	235	213	186	115	6 x ø8	1.0
280/310	VS031000	306	286	256	156	6 x ø8	2.0
355/400 450/500	VS035500	464	438	402	220	6 x ø10	4.5
560/630	VS056000	639	605	569	255	8 x ø10	6.5
710	VS071000	708	674	635	250	8 x ø10	7.5
800/900	VS080000	910	872	797	340	8 x ø10	15.5

Protection Guard

Size	Part Number	D	LK	d	a x β	Weight kg
190/225	BG019020	190	213	7	3 x 1200	0.3
280/310	BG025020	230	286	7	3 x 1200	0.3
355/400 450/500	BG040002	412	438	8.5	3 x 1200	0.6
560/630	BG056003	570	605	11.5	8 x 450	1.5
710	BG063003	630	674	11.5	4 x 450	1.8

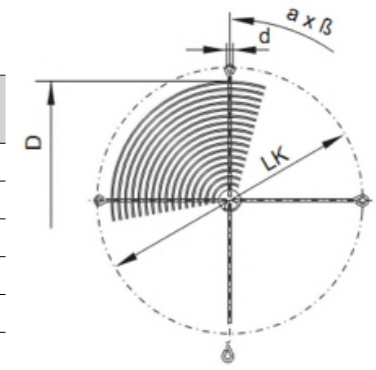
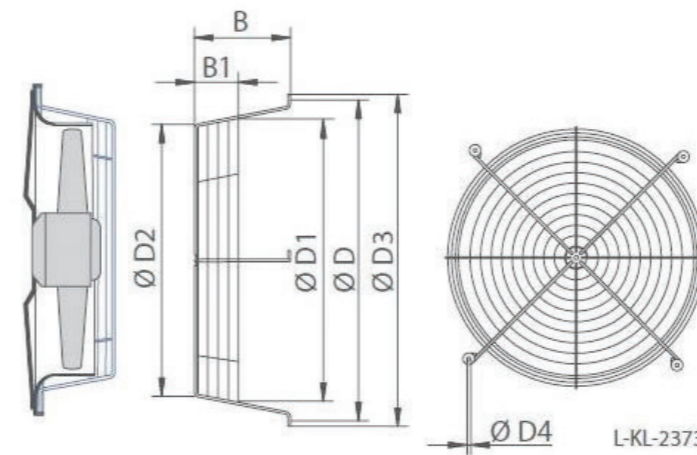
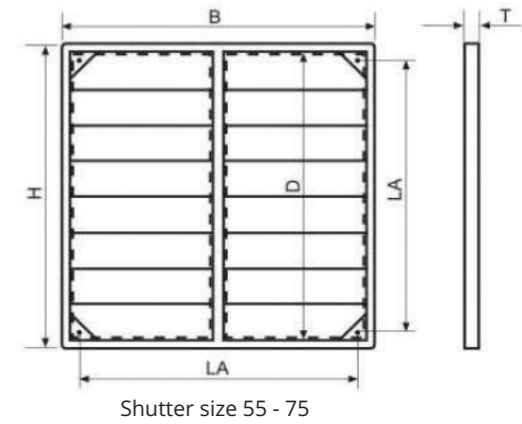
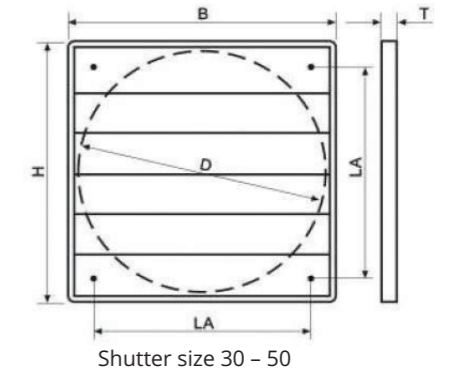

Plate Fan Shutter

Size	Part Number	D	H / B	LA	T
25	SK060002	258	294	232	26
30	SK060011	310	346	276	26
35	SK060012	360	397	310	26
40	SK060013	422	462	366	26
45	SK060014	462	501	395	31
50	SK060015	505	548	443	31
55	SK060016	563	603	520	28
65	SK060017	655	696	628	31
71	SK060018	720	760	692	40
75	SK060035	750	790	722	40



Impeller Side Guard

Size	Part Number	B	B1	D	D1	D2	D2	D4
350	PG286215	154	95	422	380	387	444	7
400	PG287758	145	64	500	431	424	522	7
450	PG286217	187	131	560	487	455	582	7
500	PG286218	187	83	615	539	522	637	7
560	PG286202	223	120	658	597	569	680	7
630	PG286219	231	127	720	682	677	724	7
710	PG286201	295	152	835	743	701	857	9.5

All dimensions shown in mm

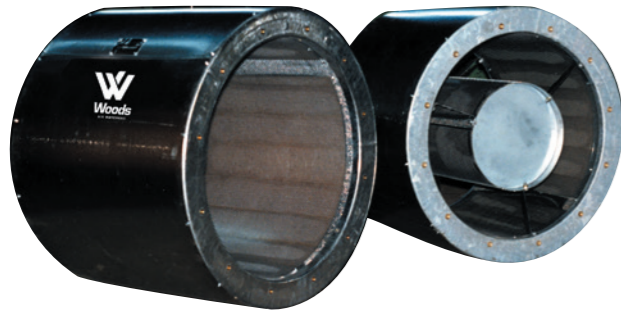

Silencers

PERFORMANCES

The performances are derived from tests to BS848. Measurements of fan noise are made with and without the silencer in position. The difference between recorded levels is the dynamic (with airflow) attenuation or insertion loss of the silencer. Type B silencers may be directly coupled to both inlet and outlet flanges of the fan. When type C silencers are directly coupled to the fan flanges they are most effective on the outlet. A spacer duct of 1D length between the fan inlet flange and a type C silencer is necessary to ensure maximum performance.

Note: C type silencers mounted close to a fan may effect the aerodynamic performance.

CONSTRUCTION

Casings are of rolled, pre-galvanised sheet steel with spun end rings incorporating tapped inserts for fixing. Suitable fixing screws are provided with all steel silencers.

The absorbent material is acoustic grade mineral fibre with an erosion resistant facing. It is protected and contained by a pre-galvanised perforated steel sheet formed to match the fan diameter.

Cylindrical silencers shall be suitable for air pressures up to a maximum of 1000 Pa. For duct pressures in excess of 1000 Pa please enquire.

A Melinex Lining (variant code M) can be supplied for critically clean applications such as hospitals to ensure no fibre migration. The lining may also be used in moisture or grease laden conditions, such as kitchen extract systems

where the material is used to stop the ingress of grease etc. into the acoustic media.

The use of the lining also allows the silencers to be low pressure steam cleaned. Some reduction of attenuation due to the lining will be experienced.

SIZE RANGE

Type B silencer bore diameters range from 280 mm to 1000 mm metric range in lengths equal to or twice the bore diameter (1D or 2D) Pressure loss for type B silencers is the same as a plain duct.

Type C silencers have a centrally mounted absorbent pod in the airway for increased attenuation. The pressure loss due to the pod is provided in Fan Selector when selecting the C type silencer as an accessory.

The diameter range is 315 mm to 1000 mm metric range.

FINISHES

Standard finish is galvanised zinc coating to BS2989 Z2. Other finishes including epoxy paint are available to special order.

TEMPERATURE RANGE

Standard silencers are suitable for temperatures from -40°C to 300°C. When moisture resistant lining is used the continuous air handling temperature is limited to 80°C.

MOUNTING

Galvanised steel mounting feet and matching flanges corresponding to those supplied for Aerofoil fans are available.

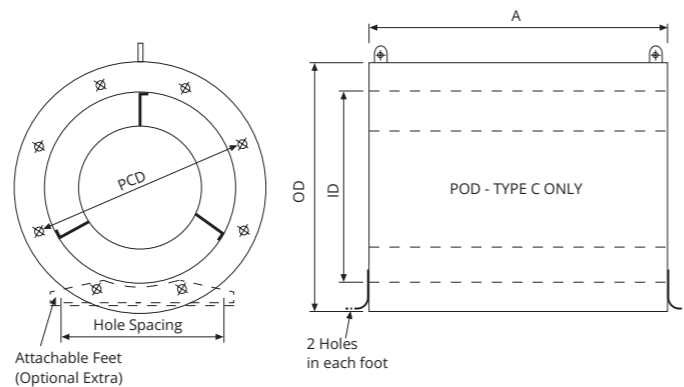

B Type Silencer

Bore Dia. mm (A)	Product Number (B1D)	OD	No of holes	PCD	Thread	Mounting Foot holes		A Length		Weight (kg)	
						Dia	Spacing	1D	2D	1D	2D
315	SB211401	415	8	355	M8	10	265	315	630	10	17
355	SB221401	455	8	395	M8	10	305	355	710	12	20
400	SB241401	500	8	450	M10	10	350	400	800	15	25
450	SB251401	600	8	500	M10	10	400	450	900	20	33
500	SB271401	650	12	560	M10	10	450	500	1000	25	41
560	SB281401	710	12	620	M10	10	510	560	1120	30	50
630	SB301401	780	12	690	M10	12	580	630	1260	35	61
710	SB311401	860	16	770	M10	10	660	710	1420	44	76
800	SB331401	1000	16	860	M10	12	750	800	1600	55	96
900	SB341401	1100	16	970	M12	12	850	900	1800	70	129
1000	SB351401	1200	16	1070	M12	12	950	1000	2000	82	157

All dimensions shown in mm

Silencer Acoustic Performance

Type B Dynamic Attenuation										Type C Dynamic Attenuation									
Bore Dia. mm (D)	Length	Octave-Band Mid Frequencies Hz								Bore Dia. mm (D)	Length	Octave-Band Mid Frequencies Hz							
		63	125	250	500	1K	2K	4K	8K			63	125	250	500	1K	2K	4K	8K
315	1D	1	2	4	9	11	10	9	7	315	1D	2	5	5	9	18	20	18	15
	2D	1	2	5	11	16	12	11	10		2D	2	6	6	12	20	25	20	17
355	1D	1	2	4	10	12	10	9	7	355	1D	2	5	6	9	18	22	19	16
	2D	2	3	6	13	17	14	11	11		2D	2	6	7	13	25	27	21	17
400	1D	2	3	5	10	13	11	9	8	400	1D	2	6	6	10	19	24	20	17
	2D	3	4	7	14	18	15	11	12		2D	3	7	8	14	29	29	23	18
450	1D	2	3	6	12	13	11	10	6	450	1D	2	4	7	13	20	23	22	17
	2D	3	4	8	17	18	15	11	11		2D	2	5	9	16	29	29	21	20
500	1D	2	3	6	13	14	10	10	5	500	1D	2	3	8	16	21	22	21	17
	2D	3	4	8	19	18	14	11	10		2D	2	4	10	20	29	30	20	26
560	1D	2	4	7	14	14	9	10	7	560	1D	3	5	8	16	20	18	19	15
	2D	3	5	9	19	18	14	12	11		2D	4	5	10	20	29	28	21	23
630	1D	2	5	7	15	13	8	9	8	630	1D	3	5	8	15	19	16	14	12
	2D	4	6	9	19	19	14	13	12		2D	5	6	10	19	29	25	21	20
710	1D	2	5	7	15	13	9	9	8	710	1D	3	5	8	15	19	15	14	12
	2D	4	6	9	19	17	13	12	11		2D	5	6	10	20	26	23	18	17
800	1D	2	5	8	16	12	9	9	8	800	1D	4	5	8	16	19	15	14	13
	2D	4	6	10	19	15	12	11	10		2D	5	7	11	22	23	21	16	14
900	1D	2	5	10	17	13	11	10	8	900	1D	4	5	9	17	19	15	14	13
	2D	4	6	12	19	15	12	11	10		2D	5	7	12	24	23	21	16	15
1000	1D	4	5	11	16	11	10	8	9	1000	1D	5	5	11	18	19	15	14	13
	2D	4	6	13	19	14	12	11	11		2D	5	7	13	26	24	20	16	16

All performances are derived from tests to BS848.

The above silencers give the following approximate dBA reductions: -

B Type 1 diameter length - 7 to -10 dBA

C Type 1 diameter length - 12 to -15 dBA

For full acoustic details and resistance to airflow for type C please refer to fan selector.

C Type Silencer (Podded)

Bore Dia. mm (A)	Product Number (C1D)	OD	No of holes	PCD	Thread	Mounting Foot holes		A Length		Weight (kg)	
						Dia	Spacing	1D	2D	1D	2D
315	SC211401	415	8	355	M8	10	265	315	630	13	19
355	SC221401	455	8	395	M8	10	305	355	710	15	24
400	SC241401	500	8	450	M10	10	350	400	800	18	30
450	SC251401	600	8	500	M10	10	400	450	900	24	39
500	SC271401	650	12	560	M10	10	450	500	1000	29	48
560	SC281401	710	12	620	M10	10	510	560	1120	35	58
630	SC301401	780	12	690	M10	12	580	630	1260	42	72
710	SC311401	860	16	770	M10	10	660	710	1420	53	90
800	SC331401	1000	16	860	M10	12	750	800	1600	66	116
900	SC341401	1100	16	970	M12	12	850	900	1800	84	150
1000	SC351401	1200	16	1070	M12	12	950	1000	2000	100	182

All dimensions shown in mm

CASED AXIAL FANS

JM Guard

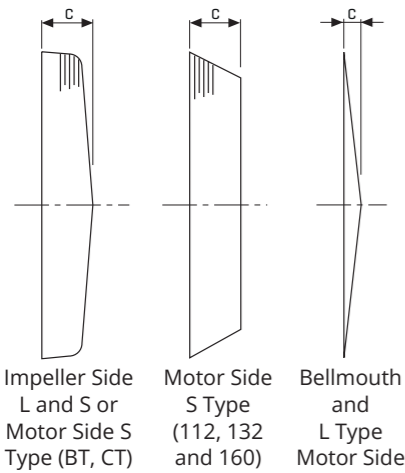
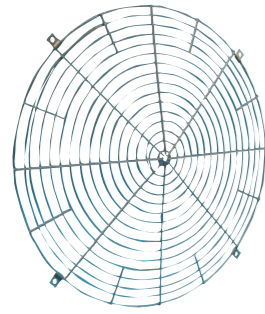

Product Number	Description	Motor Frame	Dim C	Weight kg
248853	31JM/JMP Guard Impeller (L and S) or Motor Side (S)	BT/CT	137	1.2
248854	35JM/JMP Guard Impeller (L and S) or Motor Side (S)	BT/CT	137	1.5
248856	40JM/JMP Guard Impeller (L and S) or Motor Side (S)	BT/CT	137	1.6
248855	45JM/JMP Guard Impeller (L and S) or Motor Side (S)	BT/CT	137	2
245014	50JM/JMP Guard Impeller (L and S) or Motor Side (S)	BT/CT	137	2
245074	56JM/JMP Guard Impeller Side (L and S)	N/A	137	2.5
252452	56JM Guard M/side (S)	112 Max	200	2.4
245060	63JM Guard Impeller Side (L and S)	N/A	137	2.8
252455	63JM GuardM/side (S)	112 Max	200	3
248888	63JM Guard M/side (S)	160 Max	372	3.4
245058	71JM Guard Impeller Side (L and S)	N/A	137	3.2
248887	71JM Guard M/side (S)	160 Max	372	3.4
244460	80JM Guard Impeller Side (L and S)	N/A	137	3.5
252457	80JM Guard M/side (S)	112 Max	137	3.5
248886	80JM Guard M/side (S)	160 Max	372	3.9
245062	90JM Guard Impeller Side (L and S)	N/A	137	4.2
252233	90JM Guard M/side (S)	112 Max	200	4.2
248885	90JM Guard M/side (S)	160 Max	348	5.4
244955	100JM Guard impeller Side (L and S)	N/A	137	5
252231	100JM Guard M/side (S)	112 Max	200	5
247681	100JM Guard M/side (S)	160 Max	372	6.3
249354	31JM Guard Bellmouth and Motor Side (L)	N/A	30	0.5
249334	35JM Guard Bellmouth and Motor Side (L)	N/A	30	0.5
249355	40JM Guard Bellmouth and Motor Side (L)	N/A	30	0.6
249356	45JM Guard Bellmouth and Motor Side (L)	N/A	30	0.6
249357	50JM Guard Bellmouth and Motor Side (L)	N/A	30	0.7
249358	56JM Guard Bellmouth and Motor Side (L)	N/A	50	1
249359	63JM Guard Bellmouth and Motor Side (L)	N/A	50	1.2
249360	71JM Guard Bellmouth and Motor Side (L)	N/A	50	1.4
249361	80JM Guard Bellmouth and Motor Side (L)	N/A	50	1.5
249362	90JM Guard Bellmouth and Motor Side (L)	N/A	50	1.7
249333	100JM Guard Bellmouth and Motor Side (L)	N/A	50	2

JM Bellmouth inlet - Fan with Flanged inlet only

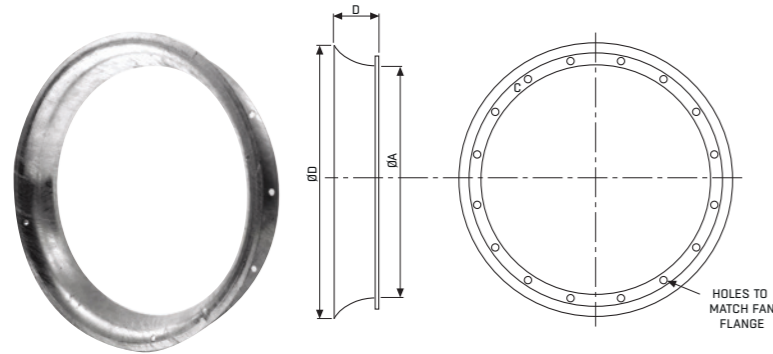

All dimensions shown in mm

Suitable for fan ØA	Product Number	C	ØD	Weight kg
315	408593	65	387	1
355	248950	85	430	1.5
400	74880	90	482	1.5
450	248952	95	545	2
500	74881	87	606	2.9
560	248953	97	665	4.5
630	74882	108	763	4.8
710	74883	126	863	5.4
800	74884	134	962	6.8
900	404842	150	1084	8
1000	74885	167	1244	17.8

CASED AXIAL FANS

Louvre shutter

Suitable for fan dia. A	Product Number	A	B	C	Weight kg
315	403715	250	300	395	1
355	403716	300	350	445	1.25
400	403717	350	400	495	1.5
450	403718	400	450	545	1.75
500	403719	450	500	595	2
560	410282	500	550	645	2.2
630	407949	603	653	748	2.4

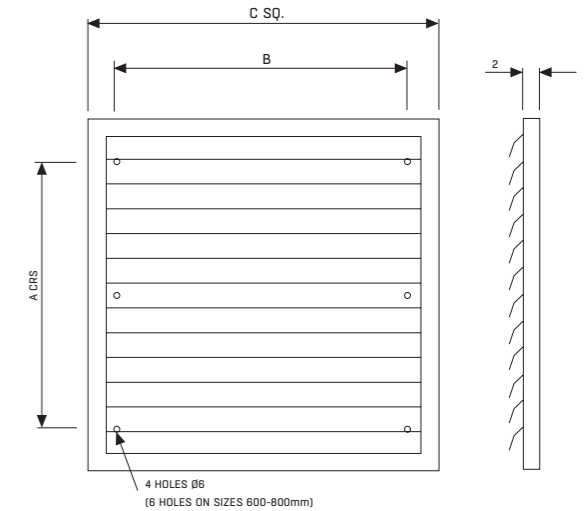

Aluminium frames, plastic shutters. Shutters must be separated from the fan mounting plane by the following minimum distances:

- Up to 500 mm Ø - 150mm
- 560 to 630 mm Ø - 200mm

Note: that under some combinations of fan speed and wind the shutters vanes may become unstable. This is more likely to occur at reduced fan speed.

Acoustic Jackets

Diameter Size (mm)	Product Number	Type
315	860676	High Perf Acoustic Jacket 315 Dia x 375 Long (JMv)
355	860677	High Perf Acoustic Jacket 355 Dia x 375 Long (JMv)
400	860678	High Perf Acoustic Jacket 400 Dia x 375 Long (JM)
450	860679	High Perf Acoustic Jacket 450 Dia x 375 Long (JM)
450	867988	High Perf Acoustic Jacket 450 Dia x 520 Long (JM)
500	863694	High Perf Acoustic Jacket 500 Dia x 330 Long (JM)
500	867784	High Perf Acoustic Jacket 500 Dia x 375 Long (JM)
500	858991	High Perf Acoustic Jacket 500 Dia x 520 Long (JM)
500	876675	High Perf Acoustic Jacket 500 Dia x 710 Long (MaXfan ²)
560	858911	High Perf Acoustic Jacket 560 Dia x 520 Long (JM)
560	876737	High Perf Acoustic Jacket 560 Dia x 654 Long (MaXfan ²)
630	858801	High Perf Acoustic Jacket 630 Dia x 520 Long (JM)
630	876676	High Perf Acoustic Jacket 630 Dia x 710 Long (MaXfan ²)



Our Acoustic Jackets are made to suit the metric Aerofoil Axial Flow Fan range (other fan ranges can be accommodated, for details please enquire). The effect of fitting an Acoustic Jacket to our 'L' type only is to reduce the amount of total sound breaking out from the fan casing only.

The effect of fitting an Acoustic Jacket to our 'L' type only is to reduce the amount of total sound breaking out from the fan casing only.

High performance acoustic jackets which typically achieve a 10-14dB(A) reduction in casing breakout noise.

Typical Construction suitable for indoors / outdoors.

- Grey silicone glass cloth inner and outer
- 50mm mineral wool insulation layer
- Sound barrier material
- Terminal box cut out included (if required/or if dimensions are available)
- Supplied complete with Velcro flap and straps with D rings

All dimensions shown in mm

Rubber Anti-Vibration Mounts

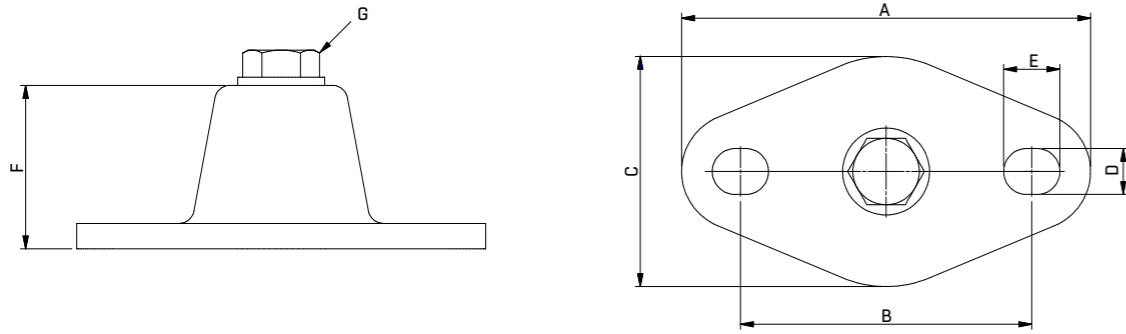

Product Code	Type	Load at 5-6mm deflection (kg)	A	B	C	D	E	F	G
505000	AV Rubber MP2-28 Yellow ISL	28	80	57	45	9	11	32	M8
505001	AV Rubber MP2-50 Blue ISL	50	80	57	45	9	11	32	M8
505002	AV Rubber MP2-80 Red ISL	80	80	57	45	9	11	32	M8

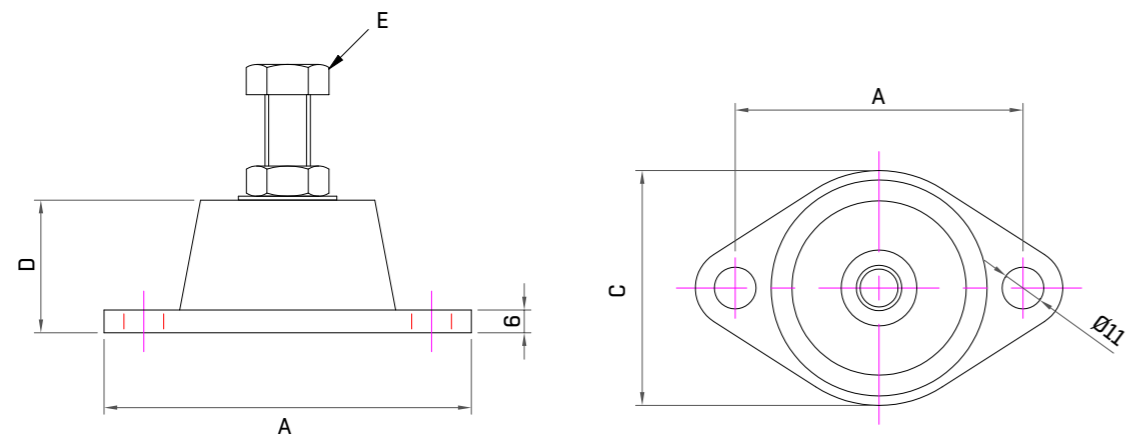

Product Code	Type	Load at 8mm deflection (kg)	A	B	C	D	E
863893	AV Rubber MP5-110 Yellow ISL	110	95	71	60	9	M10 x 25mm
863894	AV Rubber MP5-180 Blue ISL	180	95	71	60	9	M10 x 25mm
863895	AV Rubber MP5-280 Red ISL	280	95	71	60	9	M10 x 25mm
863896	AV Rubber MP6-260 Blue ISL	260	150	115	80	11	M12 x 30mm

All dimensions shown in mm

Enclosed Spring Anti-Vibration Mounts

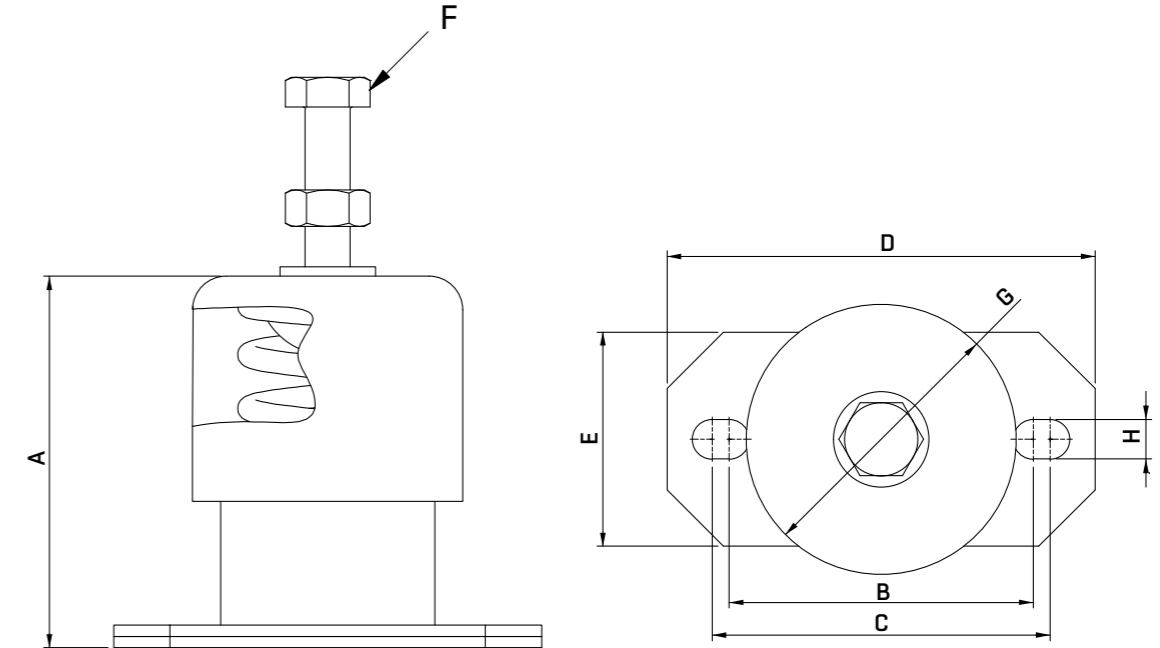

Product Code	Type	Load at 20mm deflection (kg)	A	B	C	D	E	F	G	H
505009	MMS1-L-10 Claret ISL	10	66	54	60	76	38	M8	48	7
505010	MMS1-L-15 Yellow ISL	15	66	54	60	76	38	M8	48	7
505011	MMS1-L-20 Grey ISL	20	66	54	60	76	38	M8	48	7
505012	MMS1-L-40 Green ISL	40	66	54	60	76	38	M8	48	7
505013	MMS1-L-70 Red ISL	70	66	54	60	76	38	M8	48	7
505014	MMS1-L-100 Blue ISL	100	66	54	60	76	38	M8	48	7

Product Code	Type	Load at 25mm deflection (kg)	A	B	C	D	E	F	G	H
505015	MMS1-30 Yellow ISL	30	96	85	90	110	70	M10	78	9
505016	MMS1-60 Green ISL	60	96	85	90	110	70	M10	78	9
505017	MMS1-100 Blue ISL	100	96	85	90	110	70	M10	78	9
505018	MMS1-160 White ISL	160	96	85	90	110	70	M10	78	9
505019	MMS1-250 Red ISL	250	96	85	90	110	70	M10	78	9

All dimensions shown in mm



Woods Air Movement delivers smart and energy efficient Air Movement and Fire Safety solutions to support every application area. We offer our customers innovative technologies, high quality and outstanding performance. The widest range of Air Movement and Ventilation products in the market, and strong market presence with over 100 years of experience and manufacturing of products, guarantees that we are always by your side, ready to deliver Excellence in Solutions.

**Contact our friendly sales team today
for more information**

Call: +44 (0) 1206 222 555

Email: quotations.woods@flaktgroup.com

www.woodsairmovement.com

