

AEROFOIL AXIAL FLOW FANS - HT & STANDARD

Safety, installation and
maintenance instructions

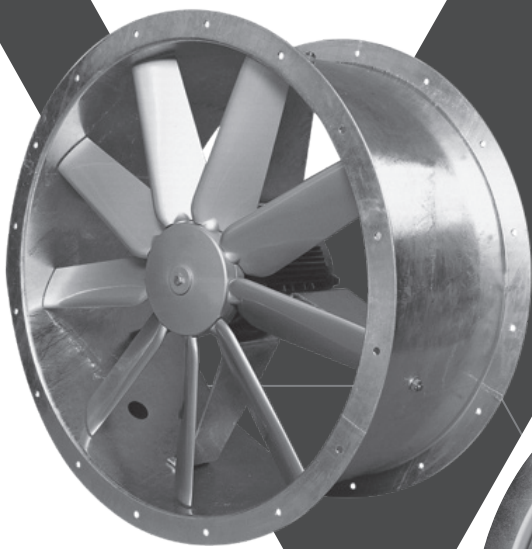

CONTENTS

PAGE

HT SERIES SMOKE VENTING EQUIPMENT

Fans for emergency operation at high ambients for a limited period

1 GENERAL SAFETY WARNING	4
2 INSTALLATION, OPERATION AND MAINTENANCE INSTRUCTIONS	4
3 SITE STORAGE, SUPPLY, INSTALLATION	4
4 OPERATING CONDITIONS	4
5 CONNECTION	5
6 CABLE	5
7 CONTROL	5
8 MAINTENANCE - HT FANS	5
9 LUBRICATION - HT FANS	6
10 TESTING (FANS AND CONTROLS)	8
11 LONG TERM RELIABILITY	8

STANDARD VENTILATION FANS

12 SAFETY	9
13 INTRODUCTION & PURPOSE - GENERAL	9
14 STORAGE & HANDLING	9
15 MECHANICAL INSTALLATION	10
16 ELECTRICAL INSTALLATION & OPERATION	11
16.1 - OVERHEAT PROTECTION	12
16.2 - BEARING TEMPERATURE, VIBRATION & LEVEL MONITORING SENSORS	12
16.3 - SPACE HEATER/ ANTI-CONDENSATION HEATER	12
16.4 - EMERGENCY-USE FANS	12
16.5 - SWITCH-ON	13
17 MAINTENANCE	13
17.1 - FASTENERS	14
17.2 - LUBRICATION	14
17.3 - INFREQUENT USE	14
18 OVERHAUL / EXTENDED MAINTENANCE	14
19 FAULT FINDING	15
19.1 - ELECTRICAL	15
19.2 - MECHANICAL	15
20 DISPOSAL	15

TABLE

1 ROUTINE MAINTENANCE PROCEDURES	16
--	----

FIGURES

1 TWO STAGE CONTRA-ROTATING INSTALLATION	17
2 FIXING ARRANGEMENT OF TERMINAL BLOCK (DRAWING NO: D258302 F)	17
3 WIRING DETAIL - THREE PHASE FANS WITH FAN HOUSING MOUNTED TERMINAL BOX (460V & 208V)	18
4 NOTES PAGE	19

**THIS LEAFLET MUST BE PASSED TO THE USER
TO ENABLE THE FAN TO BE MAINTAINED IN A SAFE CONDITION.**

HT SERIES SMOKE VENTING EQUIPMENT

Fans for emergency operation at high ambients for a limited period

1. SAFETY

Warning and safety information relevant to specific operations are contained within each section. The following warning or advice categories are used:



DANGER!

Failure to follow these instructions may result in serious injury or death to the user in addition to serious damage to the equipment.



WARNING!

Failure to follow these instructions may result in minor injury or damage to the equipment.



CAUTION!

Failure to follow these instructions may result in malfunction or damage to the equipment



DANGER!

This product contains rotating parts and electrical connections which can be a danger and cause injury. It is of paramount importance for any fan that is required to function in emergency conditions, that the installer and user must follow all relevant instructions contained within this leaflet, as well as those contained within our general Instruction leaflet, which is supplied with this product.

To ensure that fans will operate continuously during a high air temperature emergency, the electrical system must have been designed and installed to accommodate the specific emergency conditions of temperature and duration.

A maintenance procedure must be put in place and a record of the activities that have been performed must be kept.

2. INSTALLATION, OPERATION AND MAINTENANCE INSTRUCTIONS

These instructions apply to all axial fans within our range and must be read in conjunction with advice related to our standard temperature fans (see sections 12 onwards). **Note:** Where fans have a foot-mounted motor fitted, then the motor mounting feet must be positioned underneath the motor. Foot mounted motors must never be suspended from their mounting feet. If in doubt, please refer to Woods Air Movement USA (sales.us@flaktgroup.com)

3. SITE STORAGE, SUPPLY, INSTALLATION



WARNING!

When fans are stored (prior to installation), please ensure that access by un-authorized persons is prevented, by using guards, barriers or secure premises to ensure that fan impellers (which may be rotating) do not present a hazard. For more specific advice please refer to sections 12 onwards.

These instructions relate to all fans rated up to and including 572°F for 2 hours which are designed to be mounted into or on the end of ductwork that is situated outside the fire zone. All high temperature fans (designed for smoke extraction) are also suitable for use within fully immersed conditions (i.e. where fans are mounted inside the fire zone).

4. OPERATING CONDITIONS

Under emergency conditions, our fans are suitable for the temperature/time capability stated on their name plate or in accompanying documentation. e.g. 572°F for 2 hours, which denotes that a fan is suitable for a single use at an emergency condition. UL Certification for the high temperature smoke extract applications is pending (572°F for 2 hours).

Unless otherwise stated fans are suitable for continuous operation, prior to the emergency, in ambient temperatures of -40°F to +104°F. They are only suitable for start-up between -4°F to +104°F. On the fan nameplate, the maximum temperature may be shown as +104°F but when installed for emergency use, the temperature/time capability will be as shown on an additional label adjacent to the main nameplate.

5. CONNECTION

The wiring to the fan must be in accordance with the connection diagram in the terminal box.

Fans are designed for a 3-phase electrical supply. On commissioning, the rotation of the impeller should always be checked to ensure that it is running in the correct direction.

6. CABLE

Suitable fire-resistant cable must be used between the main supply, starter controls and the fan. The mains supply must be from a guaranteed or separately maintained source, to enable the fan to continue running under emergency conditions. Fan housing-mounted terminal boxes for all HT fan specifications are designed to accommodate Mineral Insulated supply cables.

7. CONTROL

High Temperature rated fans can either be run Direct-on-Line during their emergency [high temperature] operation, or via an approved frequency converter, which has been selected in accordance with EN12101-3:2015. Where required, a voltage waveform filter must also be fitted between the frequency converter and the fan drive motor. If in doubt, please seek advice from Woods Air Movement USA (sales.us@flaktgroup.com).

Our HT fans can be soft-started, and speed controlled when operating in a normal ventilation mode. Use of non-approved drives is permitted as long as the drive is by-passed from the control circuit once the fan is running at full speed. Frequency converters (also known as Variable Frequency Drives or VFDs) must not be located in the same fire compartment as the extract fans. They should instead be located within a suitable fire protected compartment, remote from the fan. VFDs must be connected to the fans using appropriate HT cable for the application and where required with screened cables to minimize the impact of EMC affects. VFDs should also be fitted with appropriately selected voltage waveform, RFI or Harmonic filters, depending on the application.

Over-heat protection, vibration sensors, bearing sensors and frequency converter motor over-heat protection circuits must be disabled during emergency mode if provided.

8. MAINTENANCE - HT FANS

For normal operation and planned preventative maintenance please refer to sections 17 and 18.

AT 3 MONTHLY INTERVALS WHEN FANS ARE NOT NORMALLY RUN

If the fan is intended for emergency use only, the resistance of its windings to earth should be measured (at 500v dc). If the Resistance value is found to be less than 10 MΩ (Megaohm), then the motor should be dried out and re-checked. Run the motor for at least 15 minutes to prevent hardening of the grease and to minimize bearing corrosion issues.

9. LUBRICATION - HT FANS



CAUTION!

It is necessary to record the number of hours the motor has operated in order to determine when bearing relubrication is required. If the motor is not running continuously, the date of installation must be recorded, since relubrication is recommended every three to six months, even if the motor has not been run during this time.



WARNING!

Beware of all rotating parts!

Grease can cause skin and eye irritation when re-greasing. Follow all safety precautions specified by the grease manufacturer.

SHIELDED/SEALED BEARINGS

Small motors (WEG NEMA 48-210T Nema frames) which are fitted with 'sealed for life' ZZ/2Z bearings (that are pre-greased), must be replaced after 20,000 running hours (if fans are continuously running). If the fan is a "dual mode" fan or if it is a dedicated fire safety (smoke extract) fan, checks should take place every 6 months to determine if the fan (motor) bearings have become noisy or appear to have become unbalanced. Check motor nameplate for determining the bearing type used.

MOTORS FITTED WITH GREASE RE-LUBRICATION POINTS

Bearing grease re-lubrication points are usually fitted to larger frame motors than those mentioned above. Regular maintenance and adherence to re-greasing procedures will prolong bearing life. Failure to do this may shorten bearing life considerably.

Maintenance includes:

- a) Attention to the overall bearing condition;
- b) Cleaning and lubrication;
- c) Detailed inspection of the bearings.

Although bearing problems may often be detected by listening for unusual bearing noise, more sophisticated equipment should be used to obtain a quantified bearing condition analysis. Bearings must be lubricated to avoid metallic and direct contact of the moving parts, and to provide protection against corrosion and wear. Lubricant properties deteriorate over time due to mechanical operation, furthermore, all lubricants are subject to contamination under working conditions. For this reason, lubricants must be renewed or replenished on a regular basis, in accordance with motor manufacturers recommendations.



NOTE!

Bearings with grease re-lubrication points must be replaced after 40,000 running hours or 5 years, whichever occurs first.

LUBRICATION INTERVALS



It should be noted that some grease types may cause higher bearing noise levels particularly at low temperatures, or when intermittent operation does not allow the running temperature to exceed +68 °F.

Please contact Woods Air Movement USA if the normal fan and motor operating temperature is below +23 °F.

Grease type, lubrication intervals, grease quantity used, and the bearing type and its associated component clearances, are all indicated on the motor nameplate. Lubrication intervals are dependent on motor size, running speed, working conditions, grease type and the ambient operating temperature. If required, please contact Woods Air Movement USA for further advice related to bearing lubrication or replacement.



NOTE!

If the supplied fan and motor assembly was intended and designed for horizontal operation but is then operated in a vertical position (i.e. with the motor shaft in the vertically up or vertically down position), then bearing lubrication intervals must be reduced by half (i.e. must be more frequent).

CORRECT GREASE QUANTITY

Correct lubrication is very important to ensure that bearings operate reliably i.e. grease must be applied correctly and in a sufficient amount. Lack of grease or excessive greasing may cause bearing damage.



CAUTION!

We recommend that one grease shot is measured in order to determine its weight, so that the number of grease shots required, can be matched to the quantity (i.e. weight) as stated on the motor nameplate.

Excessive greasing causes overheating by increasing the resistance to free movement of its rotating parts and, in particular, by the lubricant being compacted so that it loses its lubricating characteristic. An excessive application of grease may also cause it to leak into the motor, contaminating the winding. Lack of grease causes overheating due to increased friction levels between the rolling elements, outer ring and inner race, which will ultimately result in premature bearing failure.

GREASE COMPATIBILITY

Incompatibility between different grease types can cause problems.



ATTENTION

Never mix greases of different bases.

Example: lithium-based grease must never be mixed with sodium or calcium-based grease.



ATTENTION

To avoid any eventual grease incompatibility, always re-grease bearings with the grease type indicated on the motor nameplate.

As a general rule, greases with the same specification are compatible, however this is dependent on the formula. Before mixing grease types, therefore, please consult the grease supplier.

DRIVE END AND NON-DRIVE END BEARING RELUBRICATION STEPS

1. Before lubricating the bearing, clean the area around the grease re-lubrication points with clean cotton cloth;
2. With the motor running, add the amount of grease indicated on the bearing nameplate;
3. Leave the motor running for sufficient time to spread the grease on the bearing;
4. Check bearing temperature to make sure there is no significant variation.



NOTE!

On first start of the equipment or after a bearing re-lubrication, there may be a slight temperature rise for the initial 10-20 hours of running.

If the motor cannot be lubricated while it is running under normal conditions, lubrication can be carried out as detailed below:

1. Inject about half amount of required grease, and run the motor at full speed for 5 minutes;
2. Switch off the motor and inject the remaining grease;
3. Start the motor again to ensure that grease is correctly distributed within the bearing.

**CAUTION!**

The bearing life is estimated by calculations according to ISO 281:2007-02 to give a L10 life. Beyond each periodical maintenance, our recommended bearing condition check frequency is at each lubrication. Depending on the results, bearings may need to be replaced.

**CAUTION!**

Lubrication intervals are based on a bearing operating temperature of +167°F (frames 63 to 200) and +185°F (frames 225 to 500). Some designs may vary. An increase of the ambient temperature will raise the bearing temperature correspondingly. For each 59°F of temperature rise, the relubrication period must be reduced by half (i.e. must be more frequent).

**ATTENTION!**

Where motors are mounted inside fan housings, and where grease re-lubrication points have been mounted on the exterior of the fan housing, there will be an additional nameplate affixed to the product which will state the grease type, quantity and re-lubrication interval.

MOTORS WITHOUT LUBRICATORS

Where motors are not fitted with bearings that can be re-lubricated (WEG 48-210T NEMA frames), then the following steps must be taken:

Motors operating in ambient temperatures up to +122°F;

After 20,000 hours running, or 3 years, whichever is the shorter, (10,000 hours where motor speed exceeds 1800 rpm), the motor should be dismantled, shaft seals and bearings replaced and the bearings re-lubricated.

To re-lubricate motors which are mounted in an airstream with a temperature above 392°F or above (where the motor is designed for used within a Smoke Extraction fan), the special grease used has a very low fill requirement. These fans, therefore, do not have re-lubrication facilities. Any old grease must be washed out with a designated solvent. The bearings must be refilled with grease leaving the housing empty. If a bearing is removed from the rotor, it must be discarded and a new one fitted, using the approved grease.

10. TESTING (FANS AND CONTROLS)

It is recommended that fire safety systems are tested every 6 months. However, ideally, these tests should be more frequent (once per month or once every 3 months). This test must review all elements of the system [fans, controls, dampers etc.] to confirm correct operation.

Note: Fans must only be run for short periods as no thermal overloads are in circuit for emergency condition.

11. LONG TERM RELIABILITY

Maintenance Engineers should consider performing a major refit after fans have been operating for 50,000 hours or if they have been installed for a period of 10 years. If the condition of the motor winding has been seen to deteriorate during regular maintenance (as detailed within section 8), then the motor must be replaced. Motors used within Fire Safety fans must NOT be re-wound. It could potentially be extremely dangerous to refurbish such as motor using a standard motor rewind facility, as these motors are specially developed for the smoke control application. The new motor must be manufactured in accordance with current requirements as stated within the EN12101-3 specification.

Guidance on operating times before a re-fit is required can be obtained from Woods Air Movement USA on receipt of full operational information, duty cycle, "HT" category, and other nameplate data. To maintain the fan's High Temperature capability, motor replacement must be conducted by Woods Air Movement USA or our nominated service representatives.

STANDARD VENTILATION FANS**12. SAFETY****WARNING!**

Only approved, qualified personnel familiar with the assessment of hazards and risks associated with fans, and with the use of tools and test equipment required to service such fans, should install, operate and maintain the product.

**CAUTION!**

If the installer or user is unable to understand the information in this manual, or has any doubt that a safe and reliable installation, operation and maintenance of the equipment can be assured, Woods Air Movement or their representative must be contacted for advice.

**WARNING!**

When fans are retained in storage, access by unauthorised persons must be prevented with the use of guards, barriers or secure premises such that fan impellers which may be rotating do not present a hazard.

13. INTRODUCTION & PURPOSE - GENERAL

The Aerofoil Axial Flow Fan is a highly efficient air movement product, designed to operate between a temperature range of -40°F to +122°F (-4°F on starting). When operating at low temperatures, ice formation on the fan assembly must be prevented. Some fans may also have a specification which requires them to operate in a high temperature emergency condition (i.e. Smoke Extract). This capability will be identified on a special label affixed to the fan casing (see also Paragraph 16.4). Please refer sections 1 to 11 of this document for specific guidance related to our HT Series Smoke venting equipment. Each fan assembly has been manufactured to specifically to fulfil the requirement of the installation for which it was designed. No deviation from the original requirement must be implemented without referring to Woods Air Movement USA (sales.us@flaktgroup.com).

Any queries regarding safety or operating problems must be referred to your local Woods Air Movement office, sales center or representative, together with full fan/motor nameplate details. Should a fan failure occur whilst the product is under warranty, then please contact Woods Air Movement USA before any repair work is undertaken.

If speed control is to be provided by means of a frequency converter, then please seek drive selection and compatibility advice from Woods Air Movement USA or Woods Air Movement UK.

14. STORAGE & HANDLING**WARNING!**

While storing fan assemblies, please ensure that access by unauthorized personnel is prevented by using guards, barriers or secure premises, so that fan impellers, which may be rotating (wind milling), do not present a hazard.

If the fan assembly is to be stored; check immediately on receipt that it is as ordered and that it has not been damaged in transit. Where the fan is delivered in a crate (or similar) the crate must be considered as a protective device only.

The crate must not have other equipment stacked on top of it and it must not be stacked on top of other equipment.

The crate structure must not be used as a lifting aid, unless otherwise indicated.

Where a fan is packed inside a crate, a fork-lift truck or similar must be used to transport the product. The fan must be stored in a safe, clean, dry, vibration free location. If such storage conditions are not available, the motor space heater / anti-condensation heater (if fitted) should be connected to an appropriate electrical power supply to prevent motor condensation forming, while the fan should be stored in an appropriate enclosure. Each month, the fan impeller should be given a manual rapid spin to help prevent grease from hardening and possible bearing brinelling; the impeller must not be in the same angular position after rotation.

When dismantling the crate to gain access to the fan assembly care must be taken to avoid injury from sharp edges, nails, staples, splinters, etc. If the fan is to be stored for 12 months or more, then we recommend that the fan is inspected by a member of the Woods Air Movement service team before commissioning is undertaken.

15. MECHANICAL INSTALLATION



DANGER!

It is recommended that suitable safety guards form part of the installation. Such devices, and advice on safety devices, are available from Woods Air Movement USA.



WARNING!

Where the fan is delivered in a crate (or similar), the crate must be considered as a protective device only, and must not be used as a lifting aid unless otherwise indicated.



WARNING!

All lifting aids used during installation must be adequately certified to carry the weight of the equipment being lifted.



WARNING!

Always wear appropriate protective clothing (including hard hats, eye protectors and ear defenders) when working in the vicinity of the fan assembly.



WARNING!

During lifting of the fan all personnel must be clear of the area below the suspended fan.



NOTE!

Before fan assembly installation, check that no damage has occurred in transit, that there is no fan casing deformation, that the impeller rotates freely and that the fan and motor nameplate data complies with its use requirement. If the fan assembly has been stored (for an extended period) the motor winding resistance to earth must be measured (at 500V dc). Where any reading is less than 10 MΩ (Megaohm), the motor must be dried out and re-checked before it is switched on.

Fan assemblies can sometimes be very heavy (depending on fan and motor size and which ancillary equipment has been fitted, such as silencers, guards and bellmouths etc.), which can make them unwieldy during handling. They must therefore be lifted slowly to prevent damage or distortion. Proper precautions must be taken, and certified lifting aids used, to ensure that the fan is well supported and stable before lifting into position.

Flange holes or mounting feet holes can be used for lifting but more than one hole must be used to spread the load.

If special lifting points are provided, they must be used. The fan must be installed such that it is correctly positioned in accordance with the required airflow direction. An airflow indication arrow is shown on the fan nameplate. For two-stage, contra-rotating fans see Figure 1 (on page 17).

Sharp bends in the ductwork close to the fan must be avoided. Adequate room must be allowed round the fan for inspection and maintenance. Component parts of the fan assembly, including (if fitted) anti-vibration mounts, silencers, bellmouths, air operated dampers, flexible connectors (and their clips), purlin boxes, weather proofing, platforms, supports, chains and harnesses, etc. must be fully aligned before being bolted together so that no distortion or stress is placed on the equipment. Air operated dampers must be installed downstream of the fan (on the fan discharge) to ensure that fan performance is not adversely impacted.

Appropriate fasteners, with the correct torque applied, must be used to secure the fan into position. If in doubt, please contact Woods Air Movement USA for advice related to torque settings for each fastener. The fan mounting and support structure must be strong and rigid enough to take the weight and operating forces of the fan and any other weight applied during installation. Vibration isolators must be appropriate for the weight and thrust of the fan, in order to minimize the transmission of fan vibration to surrounding structures. When vibration isolators are used, flexible connectors and flexible electrical conduit must also be used. Vibration isolators and flexible connectors must not be used to compensate for misaligned component fixing points. If any component parts do not easily fit together the root cause must be investigated and rectified.

A drain hole is included within in each motor end cover and electrical connection terminal box. The motor drain hole must be located at the lowest point of the motor, when the fan is installed. Plugs which close drain holes should either be removed entirely (if condensation is liable to occur due to large variations in operating temperature) or removed periodically to allow any general build-up of condensation to drain away. The frequency of plug removal will depend on by environmental conditions and should be recorded within maintenance records.

After installation, all packing materials must be disposed of in accordance with Paragraph 20 (page 15).

16. ELECTRICAL INSTALLATION & OPERATION



DANGER!

No work must be attempted before completely isolating the fan assembly, its anti-condensation heater (if fitted), and its controls from all electrical supplies. Ensure that rotating parts come to rest.



WARNING!

Before entering the area where the fan is installed, please ensure that all fumes, dust, toxic emissions, heat etc. have dispersed from the local environment, and that the fan blades are not likely to rotate.



DANGER!

The fan assembly contains rotating parts and electrical connections which can be a danger and cause injury. If there is any doubt that a safe and reliable fan installation can be assured; Woods Air Movement USA or their representative must be contacted for advice.



WARNING!

If the fan assembly is designed for high-temperature emergency-use; it is imperative that the wiring used is rated and designed for the appropriate high temperature category, and that all switches and controls are overridden during the emergency operation. Only Frequency Converters which have been fully tested and certified in accordance with EN12101-3:2015 may be used.



CAUTION!

If the fan stops operating due to an overheat situation, the overheat protection thermostat may reset as the temperature cools and then automatically restart the fan if power is still applied.



WARNING!

Always wear appropriate protective clothing (including hard hats, eye protectors and ear defenders etc.) when working in the vicinity of the fan assembly.

Each fan assembly has either a terminal box mounted on the motor or on the fan housing. The fan assembly electrical supply must be connected to the terminal box by a qualified and competent electrician. It is good practice to fit a clearly marked isolator switch close to the fan. In addition, we recommend the use of a second clearly marked and accessible switch remote from the fan. Using two switches provides an enhanced level of safety when isolating the fan during maintenance. A suitable earth must also be connected. Sufficient cable length must be provided to allow for movement of the fan on its mountings.

A connection diagram providing wiring details is supplied with all fan assemblies (typically inside the terminal box lid). Figure 3 (page 18) show wiring terminal details. Figure 2 (page 17) shows the correct assembly sequence of terminal box parts. For recommended torque values, please request these from Woods Air Movement USA. It is essential that no lock washers or nuts are used between the motor lead eyelet, connecting link or customers supply lead eyelet (when fitted).

Electrical control circuit Fuses must be correctly selected to carry the rated starting current as indicated on the motor or fan nameplate but should only be regarded as offering protection against wiring short circuits or earth faults. Fuses are not designed to provide overload protection. To provide full protection for the motor, a starter panel with overload protection must be used. We also recommend that an electrical isolator switch is incorporated into the connection circuit and that it is of the lockable type, which will allow the operator or maintenance engineer to isolate the fan from the electrical supply before working on the assembly.

If a speed controller, or other control equipment, forms part of the system it must be able to control the fan within safe limits. When running fans at low speed, care must be taken to ensure that any shutters (dampers), which may be mounted in the airflow, will open and operate correctly. Control equipment should be securely located, and should not be, or cause, a radiation hazard.

Fans with a fan housing-mounted terminal box must have their electrical supply cables routed through an entry point in the side of the terminal box. Unused entry points must be sealed with weatherproof plugs or grommets. Fans with a motor-mounted terminal box must also have its electrical supply routed through an entry point in the side of the terminal box.

Cables must be routed via a gland assembly. The gland assembly should be tightened sufficiently to hold the cable and provide a weatherproof seal, but it must not be over-tightened.

16.1 OVERHEAT PROTECTION

Motor overheat protection (if fitted) can be enabled on all single-phase and three-phase motors and can be achieved by using either thermostats or thermistors. Protection device connected options are listed below:

- Where single-phase or three-phase motors have a full load current of up to and including 6.3 Amps: thermostats can be wired in series. Where the unexpected re-closure of self-resetting of a thermal cut-out can cause a hazard, or is prohibited by regulation, it must be connected into a control circuit that will not allow the fan to restart until the circuit has been manually reset.
- Where single-phase or three-phase motors have a full load current above 6.3 Amps: thermostats must be wired to separate terminals (K – K) within the terminal box; they operate by opening and closing, depending on the temperature and must be wired to directly control the motor start contactor. Where thermistors are used these must be wired to separate terminals (S –S) within the terminal box; they operate by changing their resistive value with temperature and must be wired to control the motor start contactor via a suitable relay.



NOTE!

When the fan is intended to be used for emergency high temperature operation, overheat protection must be passed in the event of an emergency (see Section 16.5).



NOTE!

When a motor cools down, an over-heat protection thermostat will reset. However, to maintain safe operation, the motor must not be allowed to start until the motor start contactor is manually reset.

16.2 BEARING TEMPERATURE AND VIBRATION MONITORING SENSORS

If monitoring sensors are fitted into the fan control system, then they must be wired to automatically switch the fan off if a fault occurs, or to provide a fault indication. If the fan is automatically switched off by a monitoring sensor the control system (via a PLC for example), then the fan is must be fully isolated from the electrical supply, so that it will not automatically reset and re-start. If the fan is designed for emergency use, then the control system must ensure that all monitoring devices are overridden so that the fan is immediately switched on during an emergency situation (see Section 16.4).

16.3 SPACE HEATER / ANTI-CONDENSATION HEATER

If monitoring sensors are fitted into the fan control system, then they must be wired to automatically switch the fan off if a fault occurs, or to provide a fault indication. If the fan is automatically switched off by a monitoring sensor the control system must ensure that the fan is fully isolated from the electrical supply, so that it will not automatically reset and re-start. If the fan is designed for emergency use, then the control system must ensure that all monitoring devices are overridden so that the fan is immediately switched on during an emergency situation (see Section 16.4).

16.4 EMERGENCY-USE FANS

Where the fan assembly is designed for emergency-use (smoke-extraction) at high temperature, the temperature / time capability of the product will be shown on a special label adjacent to the main nameplate. We recommend that an automatic control system, or a clearly marked remotely sited emergency-use switch, is fitted to override all other switches and controls, so that the fan is immediately switched on when an emergency situation occurs. The only exception is where a matched and approved Frequency Converter drive is fitted, as this can remain “in-circuit” if appropriately selected. If you require further information or advice, please contact Woods Air Movement USA directly. Also, please refer to sections 1 to 11 of this document for more detailed guidance related to our HT Series fans.

Appropriately rated high temperature cable must be used to supply power to the fan, while the electrical supply must be from a guaranteed or separately maintained source to enable that the fan continues to run during the emergency condition. After such an emergency the fan must be removed, refurbished or safely disposed of (see Paragraph 20), and replaced as necessary.

16.6 SWITCH ON

Before switching on, confirm that the electrical supply is fully compliant with the requirement of the motor as detailed on the motor or fan nameplate, that the fan is correctly installed, all component parts and fasteners are secure, safety guards are in place and no loose items or associated equipment are present in the vicinity.

Immediately after switch-on check that the rotation direction is correct. For three phase motors, if the rotation direction is incorrect, then this can be rectified by interchanging any two incoming phase connections of the electrical supply at the motor terminal block.

Check the assembly for smooth, low vibration running, and check that the current consumption is within the full load current specified on the nameplate. The fan motor must not be repeatedly or rapidly switched on and off as this could cause overheating of the motor or its associated wiring connections

17. MAINTENANCE



DANGER!

No maintenance work must be attempted before switching off and completely isolating the fan assembly, its anti-condensation heater (If fitted), and its controls, from all electrical supplies and allowing the rotating parts of the fan to come to rest.



WARNING!

Before entering the area ensure that all fumes, dust, toxic emission, heat etc. have dispersed from the local environment, and the fan blades are not likely to freely rotate.



WARNING!

All lifting aids used during maintenance, and all lifting points utilised, must be adequately certified to carry the weight of the equipment being lifted. (See paragraph 15).



WARNING!

Always wear appropriate protective clothing (including hard hats, eye protectors and ear defenders etc.) when working in the vicinity of the fan assembly.

Fan assembly maintenance must be carried out by appropriately qualified and competent personnel using the correct tools and equipment. A regular maintenance schedule should be established, and a record kept. Recommended maintenance intervals are given within Table 1 (page 16).

Where the environment is particularly dirty, it may be necessary to reduce maintenance / service intervals. Internal and external fan surfaces may be cleaned with low pressure clean water and non-abrasive additives. Water or liquid cleaning agents must not be directed at motor drain holes, as this could cause liquid ingress that then results in damage to the product.

After maintenance has been conducted and before the fan is re-started, always ensure that there are no loose items of equipment present in the vicinity of the fan, that all safety guards, chains or steel ropes, etc., are properly secured into their original location, and that any temporary device used to stop the fan blades from rotating has been removed.

17.1 FASTENERS

It is essential to ensure that all fan assembly fasteners are secure. When examining and checking the security of fasteners during routine maintenance (see Table 1 Items 10 and 11), any fasteners which have locking devices fitted or are painted over, need not be disturbed if it can be seen that they are secure. Any locking devices that are disturbed during maintenance must be discarded and replaced with new identical devices. Thread forming screws must have locking compound applied when being reused. Any fasteners which have no locking devices fitted and are not painted over, must be checked at 95% of their original torque setting to ensure that no unnecessary disturbance of the fastener has occurred. Please refer to Woods Air Movement USA for advice in relation to specific fastener torque values.

17.2 LUBRICATION

In addition to routine maintenance, motor bearings will, in the longer term, require attention. If motor bearings are greased through extended lubricators, then the required quantity of grease must periodically be applied in accordance with information stated on the fan or motor nameplate and/or as per any instructions provided. A fully compatible grease type must be used, and it is essential that all traces of water and dirt are removed from around the grease points and that a clean grease gun is used. It is only necessary to apply a small amount of pressure when injecting the specified quantity of grease into the re-gearing point. If grease injection requires the maintenance engineer to apply a high pressure, then the cause should be investigated. Grease points are generally located close to the fan housing-mounted terminal box. Where motors require re-lubrication, a separate instruction is normally issued with each fan/motor configuration. This gives details of lubrication intervals and well as the type and quantity of grease to be used.

If further details are required, Please contact Woods Air Movement USA directly.

17.3 INFREQUENT USE

If the fan assembly is used less frequently than once a month, or is designed for emergency-use only, the following additional maintenance procedures must be carried out, and a record kept:

- Resistance of motor windings to earth, must be measured (at 500V dc) each month. If these readings are less than 10 MΩ (Megaohm), the motor must be dried out in a warm airflow (typically at +104°F) and re-checked before running the motor.
- The fan should be operated between 15 and 30 minutes each month ensure that correct lubricant conditions are maintained within the bearings (i.e. to prevent grease hardening).
- An 'emergency-use' system should be run continuously for a minimum of fifteen minutes each month. The test should not only confirm that the fan operates correctly but must also ensure that the emergency use control system overrides all other control devices (except where matched frequency converters are used) (see Paragraphs 1 to 11 and 16.4 for more information).
- If space heaters / anti-condensation heaters are fitted, check each month that they automatically switch on (i.e. they are drawing current) when the motor is switched off.

18. OVERHAUL / EXTENDED MAINTENANCE

Advice on motor overhaul procedures, bearing /seal replacement, motor replacement, motor rewinding, spare parts, condition monitoring, vibration analysis, refurbishment, etc. is available from Woods Air Movement USA.

For emergency use fans, we recommend that motor shaft seals and bearings must be replaced after 20,000 hours or 5 years of normal operation whichever occurs first.

After 40,000 hours of running, we strongly recommend that a qualified and competent electrician performs a motor "health check" (as described within section 8, Fault finding) to determine the motor insulation condition.

Where the fan is to be used for an emergency (smoke extraction) operation, if motor insulation readings are less than 10 MΩ (Megaohm), then to ensure that adequate insulation life is available should the fan be required for emergency operation, we therefore recommend that the motor must be replaced with a new motor, which has been manufactured in accordance with current requirements as stated within the EN12101-3 specification



NOTE!

When dealing with High Temperature Smoke Extract fans, only an authorized company may undertake the maintenance. Failure to do so may invalidate our warranty. The motor manufacturer's specification sheets are available through Woods Air Movement USA. After overhaul/extended maintenance the fan assembly must be correctly installed back into its original position in accordance Paragraphs 12, 13, 14 and 15 of this document.

After conducting overhaul /extended maintenance the fan assembly must be correctly installed back into its original position in accordance Paragraphs 12, 13, 14 and 15 of this document. For advice on "switching on" after maintenance, please refer to paragraph 16.5.

19. FAULT FINDING

Please refer to the safety warnings ("attention" items) stated within paragraph 17.



NOTE!

Routine maintenance procedures detailed in Paragraph 17, and Table 1 (page 16), of this document are designed to help keep your fan operational and fault free.

19.1 ELECTRICAL

Check that electrical connections to the fan are secure and are in accordance with the associated wiring connection diagram.

Check that the voltage applied at each fan terminal is as specified on the fan nameplate and is balanced. Measure the current on each phase (one phase in the case of single-phase motors) of the motor in turn and check that the current consumption is within the full load current specified on the motor or fan nameplate.

Measure each motor winding to earth, and between each winding, using a 500V dc insulation tester. If the reading is less than 10 MΩ (Megaohm) the reason is likely to be dampness within the motor. To dry out the motor place it in a warm dry airstream (typically at +104°F) and regularly monitor the motor until the insulation reading is restored to 10 MΩ (Megaohm) or greater. If the reading remains at less than ten, then this could indicate that a break-down in motor winding insulation has occurred, which may require the motor to be either rewound/overhauled (standard temperature machines) or replaced with a new motor which been manufactured in accordance with current requirements as stated within the EN12101-3 specification. (smoke extraction machines).

If a smell of burnt motor insulation is detected, then please seek immediate advice from Woods Air Movement USA.

19.2 MECHANICAL

Check that there are no obstructions to the motor shaft or impeller blades, that the blades are clean, and that there are no loose components, items or debris in the vicinity.

Rotate the motor shaft by hand. Investigate any grinding noises, internal chaffing, rubbing or stiffness. If any of these defects are observed, this may indicate that bearings require lubrication or replacement.

Ensure that all fasteners are secure and tightened to the correct torque values.

20. DISPOSAL

Metal components of the fan/motor should be segregated and separately recycled. The following items of material should be safely disposed of in accordance with local health and safety regulations:

- electrical lead coverings,
- motor winding insulation materials,
- bearing lubricant,
- motor/fan terminal block,
- paintwork,
- plastic parts,
- packing materials,
- silencer infill (Note that a face mask and gloves must be worn when handling the infill. If the infill is particularly dry or is damaged it should be damped down before disposal),

TABLE 1

Routine Maintenance Schedule	Every 6 Months	Every 12 Months	Comments
1. Examine fan guards (if fitted)	✓		Remove any debris that may have accumulated round or on the guard surface.
2. Examine motor cooling fins	✓		Remove any material or dirt which has build-up between the motor cooling fins.
3. Examine impeller for dirt build-up or any physical damage	✓		Remove any build-up of dirt. Ensure impeller is secure. Replace impeller if it is damaged.
4. Check condition and tautness of fan safety support chains/harnesses/ropes (if fitted)	✓		Clean and inspect safety supports. Replace if there is any deterioration / corrosion detected.
5. Examine and operate vibration sensors (if fitted), and temperature sensors (if fitted)	✓		Check operation using built-in sensor test features or dummy signals. Check that the fan is automatically switched off, or that a warning indication is provided, when the sensors / switches indicates a fault.
6. Examine condition of safety guards (if fitted) and associated fasteners	✓		Clean safety guards. Replace if there are any signs of excessive corrosion or damage
7. Check operation of space heater / anti-condensation heaters (if fitted)	✓		Switch off power to the motor. Check that the anti-condensation heater is energised (i.e. it is drawing current).
8. Examine the clearance between the fan impeller blade tips and fan housing. Check the angle, and the security of the impeller blades		✓	Ensure that the gap between the impeller blade ends and the fan housing is even and adequate. If in doubt, please contact Woods Air Movement USA for advice related blade tip gap. Ensure that the impeller blades are secure. Blade angle must not be changed before contacting Woods Air Movement for advice.
9. Check torque of fixings used to secure the fan to its support structure.		✓	It is essential to confirm that all fixings are properly fitted, are tight, and are fully driven home (see Paragraph 17.1). If in doubt, please contact Woods Air Movement USA for advice related to the torque value of a particular fastener.
10. Examine motor, fan and ancillary equipment fixings		✓	It is essential to confirm that all fixings are properly fitted, are tight, and are fully driven home (see Paragraph 17.1) If in doubt about the torque of a fastener contact Woods Air Movement USA Ltd for advice.
11. Check movement (deflection) of vibration isolators (if fitted)		✓	Check freedom of movement. Tighten anti-vibration mount fixings if necessary.
12. Check motor voltage and current consumption		✓	Ensure voltage and full load current are as specified on the motor nameplate
13. Inspect paintwork / galvanising finish		✓	Treat any areas of damage with suitable anti-corrosion paint.
14. Grease motor bearings		✓	Check requirement in accordance with paragraph 17.2
15. Check fan assembly wiring		✓	Check security and condition of all wiring (including the earth).
16. Check fan operation for excessive vibration levels		✓	Vibration levels, whilst the fan is operating, should not be excessive. If levels are seen to have increased since the previous inspection, the fan must not be operated until the root cause has been identified and rectified.

FIGURE 13

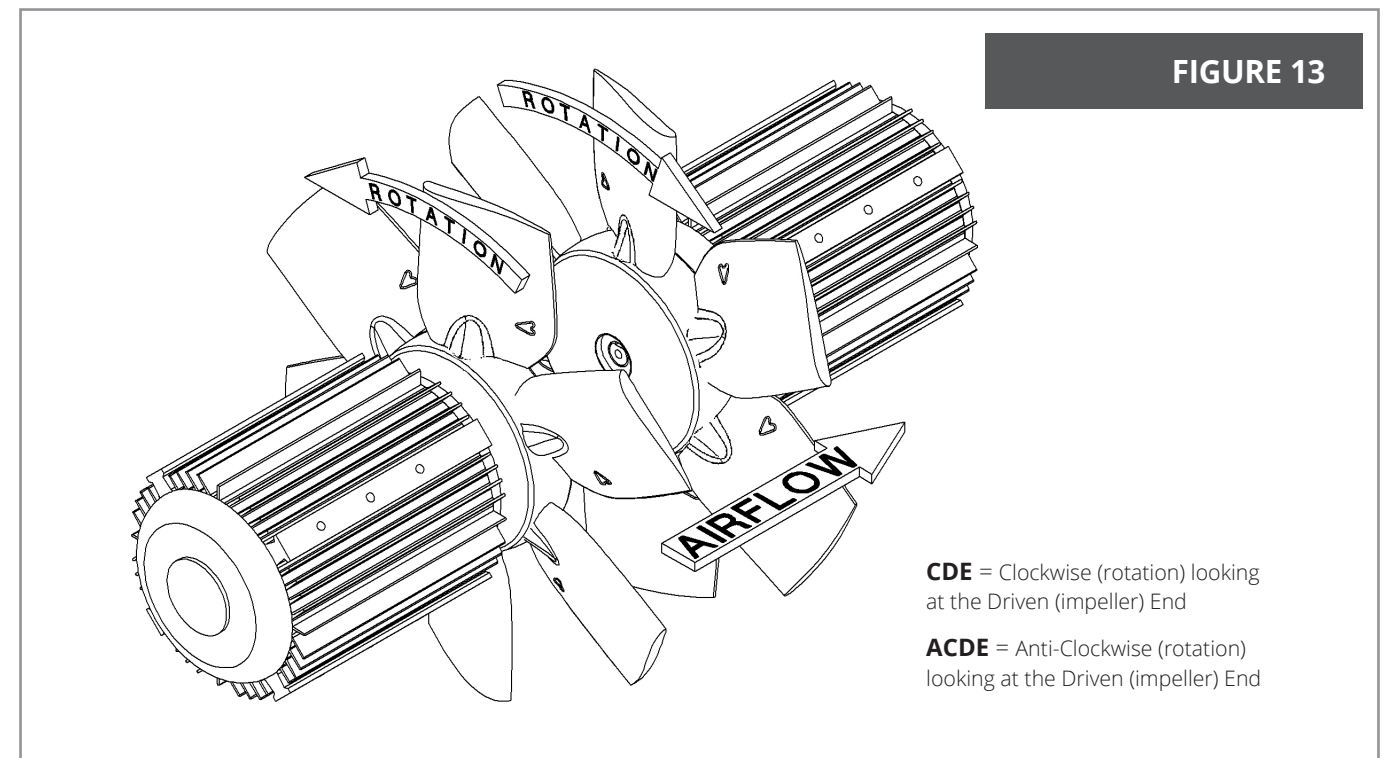

A STANDARD TWO STAGE CONTRA-ROTATING AXIAL FAN COMPRISES 1 OFF FORM A RIGHT-HAND IMPELLER FOLLOWED BY 1 OFF FORM B, LEFT-HAND IMPELLER

This arrangement does not apply to: identical fans in series or fans fitted with guide vanes.

FIGURE 2

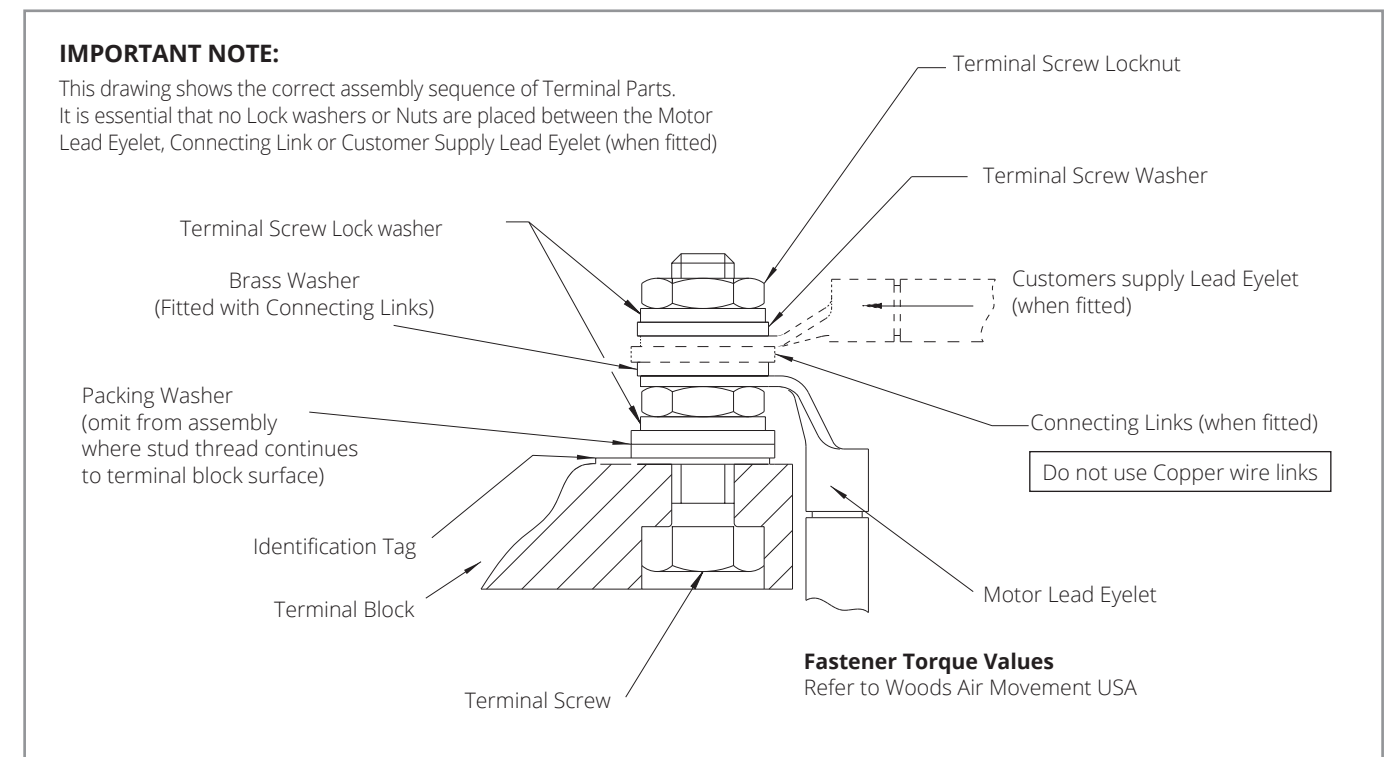

FIXING ARRANGEMENT OF TERMINAL BLOCK

Diagram only applies to HT (high temperature smoke venting fans).

FIGURE 3

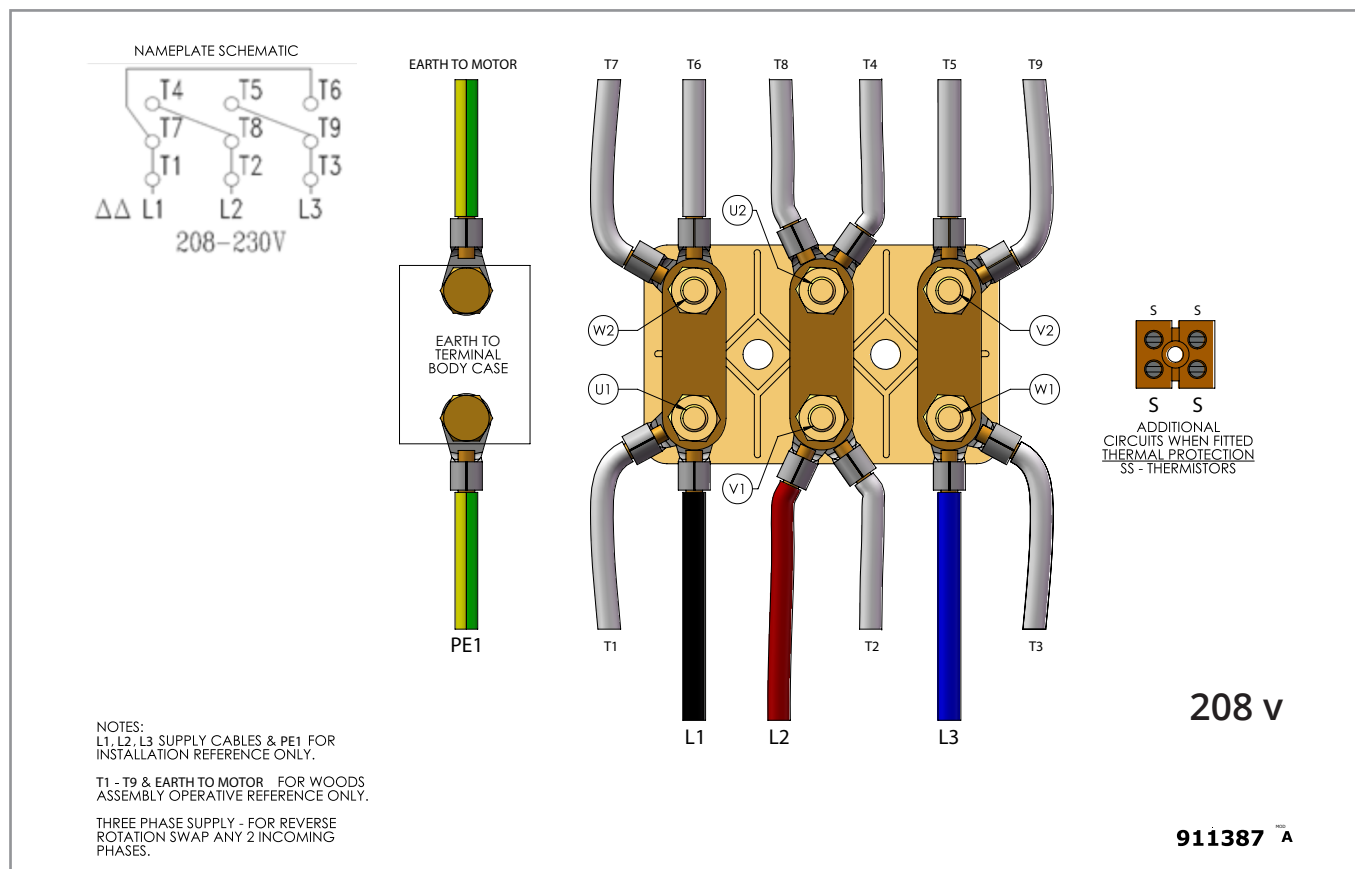
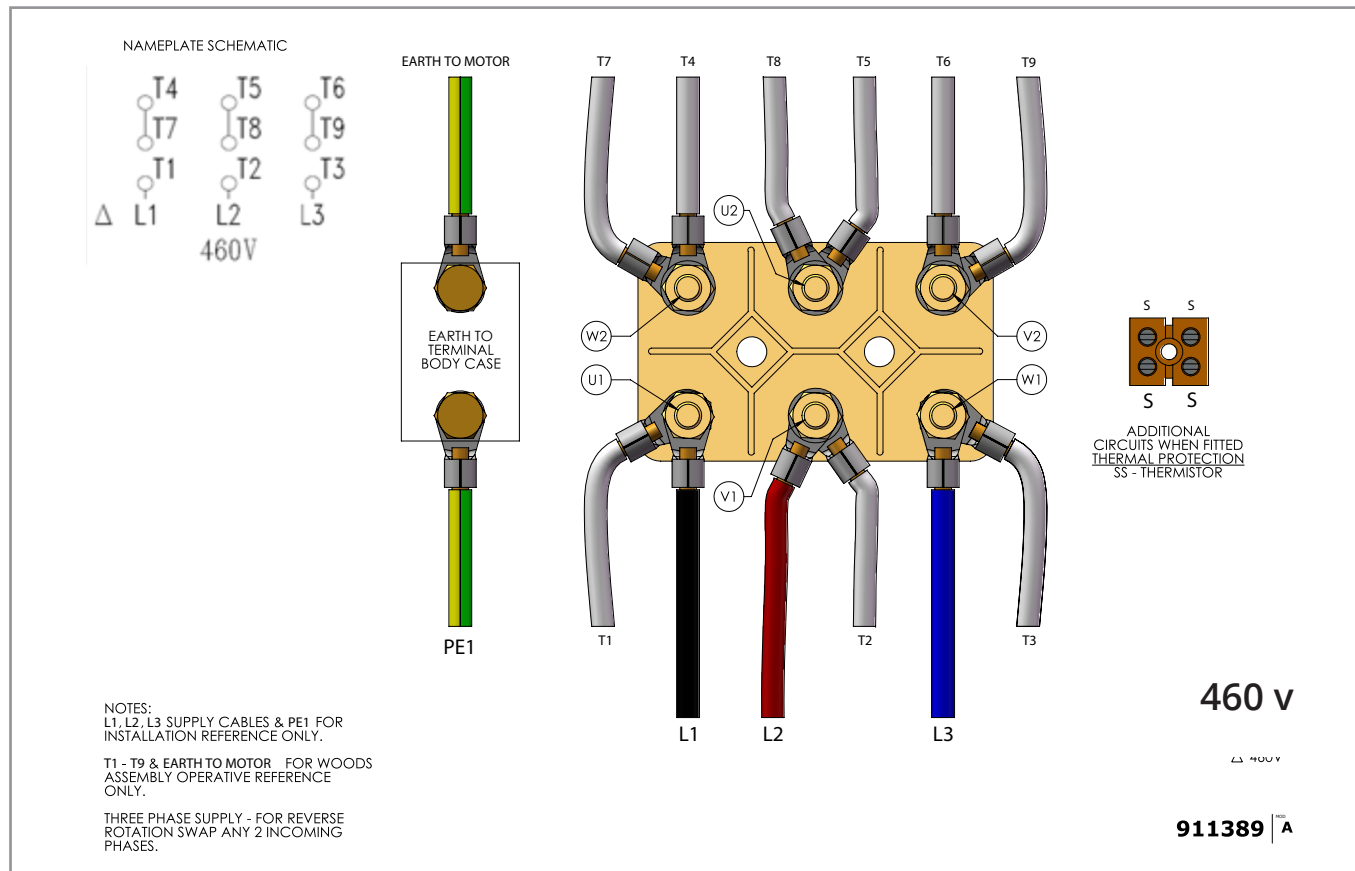



Woods Air Movement delivers smart and energy efficient Air Movement and Fire Safety solutions to support every application area. We offer our customers innovative technologies, high quality and outstanding performance supported by more than fifty years of accumulated industry application experience. The widest range of Air Movement and Ventilation products in the market, and strong market presence with over 100 years of experience and manufacturing of products, guarantees that we are always by your side, ready to deliver Excellence in Solutions.

**Contact our friendly sales team today
for more information**

tel: 629.335.9888

Email: sales.us@flaktgroup.com

www.woodsairmovement.com