

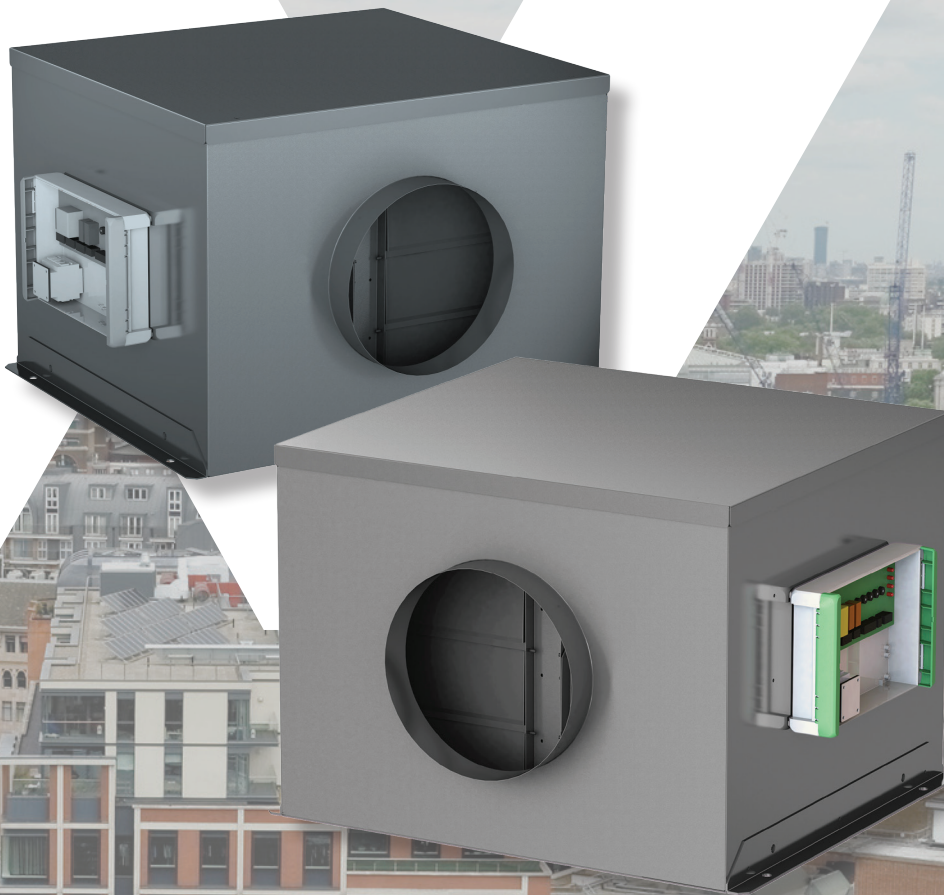

# WOODS BOX FANS EC SINGLE & TWIN







## CONTENTS

### EC SINGLE BOX FANS

Overview .....	3
Technical Details	
Performance Charts.....	4
Performance Table .....	4
Product and Electrical Data .....	4
Drawings & Dimensions .....	5
Wiring Diagrams .....	6

### EC TWIN BOX FANS

Overview .....	7
Technical Details	
Performance Charts.....	8
Performance Tables .....	8
Product and Electrical Data .....	8
Drawings & Dimensions .....	9
Wiring Diagrams .....	10

## EC SINGLE BOX FANS

### PRODUCT FACTS

- Volume flows up to 3.4 m<sup>3</sup>/s
- Static pressures up to 800 Pa
- EC motors
- Available in 50 Hz only
- Sound-proof cabinets, low breakout noise levels
- Low SFP to help achieve L2 regulations
- Speed controllable
- ErP compliant
- Plug and play fitted control panel
- Compact design

### ELECTRICAL SUPPLY

- 220-240V / 50Hz / 1Ph

### TEMPERATURE RANGE

- Maximum working temperature: up to 50°C depending on size

### SIZES

- 150, 200, 250, 315 & 350 mm

### CONSTRUCTION

Galvanised steel casing of thickness 0.9mm to 1.2mm depending on the size and model. Standard construction suitable for internal and/or external application, power coated on request.

Top access is provided as standard, bottom access option is available on request.

The units are lined with 20mm Barafoam 'O' class liner with 6mm barrier mat layer which significantly reduces noise breakout.

### IMPELLER

High efficiency backward curved centrifugal impeller.

### MOTOR

This product is fitted with EC motors to optimize energy savings and can be controlled via a 0-10V signal providing highest degree of controllability.

### INSTALLATION

These fans can be mounted vertically or horizontally. The external use models are fitted with removable discharge cowl. Bottom inlet also available on request.

### FAN CONTROLLER

The fans are fitted with plug and play control unit designed to work with BMS systems as:

- Fault Out
- VFC Enable
- VFC Boost
- Remote Speed control

### ACCESSORIES - CONTROLLERS

The range of accessories include duct clamps and silencers. A quick reference guide is shown below.



CFC



BDER



0-10V Pot



PIR

Note: The ErP legislation Reg 1253 states that a multi-speed drive or a variable speed drive must be used with this range of products.

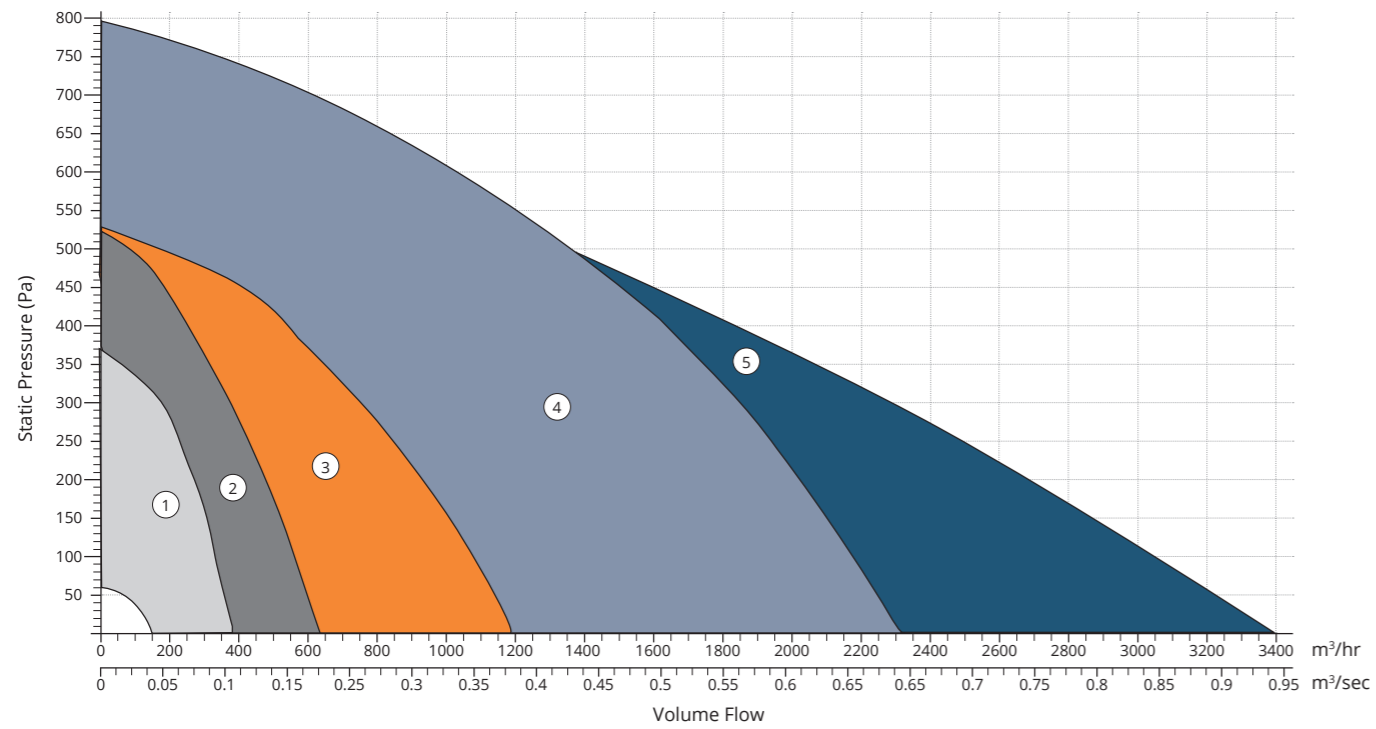

Performance Table

Ref	Product Code	M3/s @ Pa (Static)												
		0	10	20	30	40	50	60	70	80	90	100	110	120
1	Woods EC Single Box 150	0.05	0.04	0.04	0.03	0.03	0.02	0.01						
2	Woods EC Single Box 200	0.07	0.06	0.06	0.05	0.05	0.04	0.03	0.02					
3	Woods EC Single Box 250	0.13	0.12	0.11	0.10	0.09	0.07	0.06	0.04					
4	Woods EC Single Box 315	0.26	0.25	0.24	0.23	0.22	0.20	0.19	0.17	0.15	0.13	0.10	0.07	0.03
5	Woods EC Single Box 350	0.38	0.35	0.33	0.30	0.27	0.24	0.20	0.17	0.13	0.08	0.02		

Product and Electrical Data

Ref	Product Code	Product Number	Electrical Supply	RPM	Rating (kW)	Full Load Current (A)	Starting Current (A)	Sound level dB(A) (3m)*
1	Woods EC Single Box 150	EC150101	230 V/50Hz/1ph	4320	0.05	0.46	0.46	29
2	Woods EC Single Box 200	EC200101	230 V/50Hz/1ph	3200	0.83	0.75	0.75	13
3	Woods EC Single Box 250	EC250101	230 V/50Hz/1ph	2510	0.17	1.4	1.4	29
4	Woods EC Single Box 315	EC315101	230 V/50Hz/1ph	2435	0.47	3.0	3.0	41
5	Woods EC Single Box 350	EC350101	230 V/50Hz/1ph	1850	0.5	2.2	2.2	36

\* Sound power levels are average dB(A) at 3m distance over sphere, under free field conditions and are presented for comparative purposes only. Values shown are those at the mid-point of the performance curve. For ErP efficiency ratings and grades, please refer to our Fan Selector for more information.

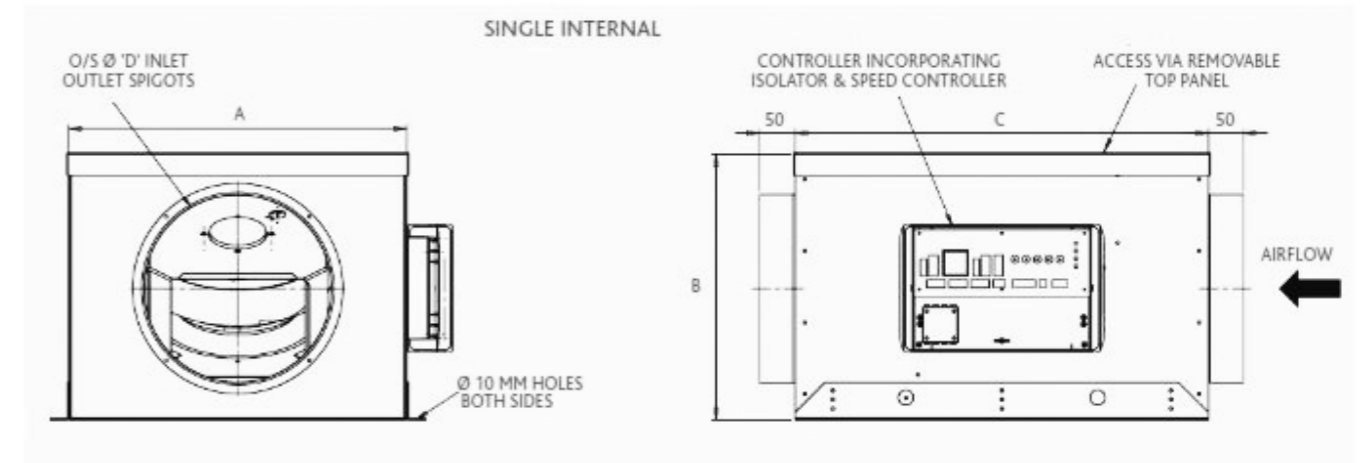

Dimensions

Ref	Product Code	A	B	C	D	Weight (kg)
1	Woods EC Single Box 150	250	250	300	150	10
2	Woods EC Single Box 200	350	250	400	200	15
3	Woods EC Single Box 250	450	350	550	250	27
4	Woods EC Single Box 315	550	400	600	310	33
5	Woods EC Single Box 350	650	550	650	350	47

1ph Wiring Diagram

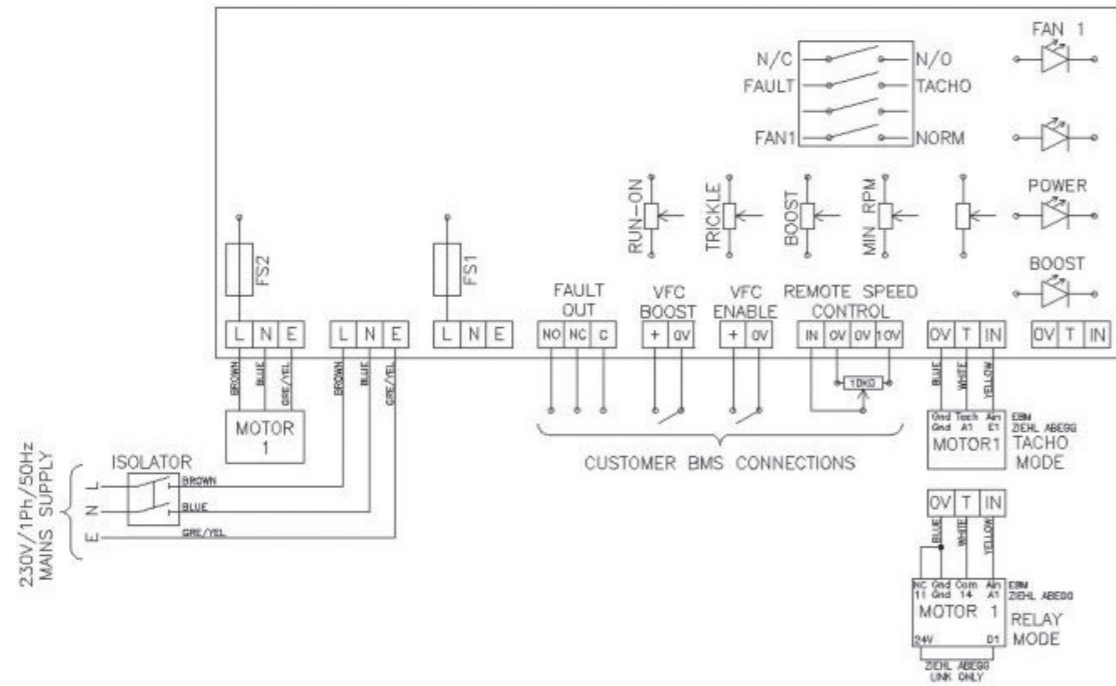

3ph Wiring Diagram

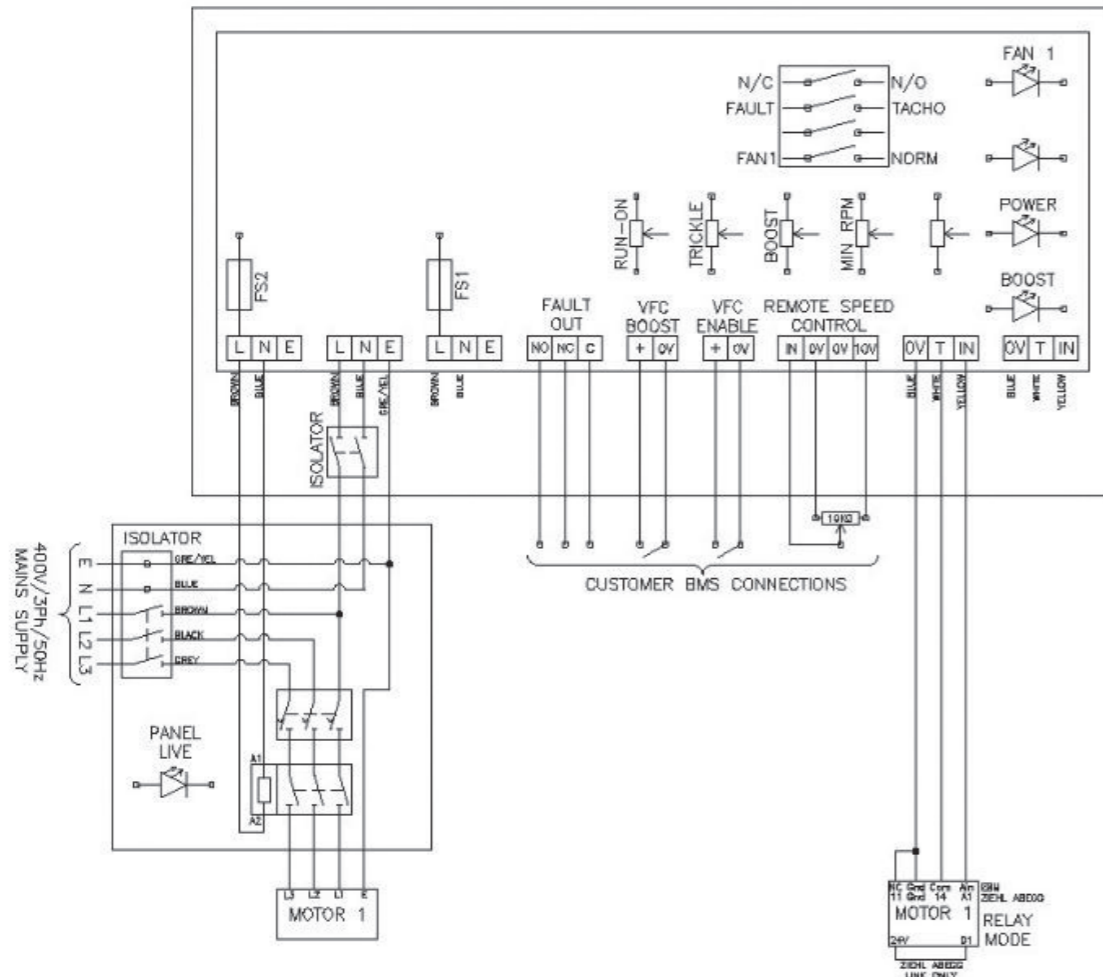

EC TWIN BOX FANS

PRODUCT FACTS

- EC Motors
- Suitable for internal & external as standard
- Plug & play fitted control panel
- Low breakout noise levels
- Low SFP to help achieve L2 regulations
- Compact design
- As standard supplied with TOP access
- ErP Compliant
- Auto Changeover Panel IP65

ELECTRICAL SUPPLY

220-240V / 50Hz / 1Ph  
380-420V / 50Hz / 3Ph (450 and 560 size only)

SIZES

150, 200, 250, 315, 350, 450 & 560 mm

CONSTRUCTION

Casings is manufactured from galvanised steel 0.99mm to 1.2mm thick depending on the model.

Standard construction suitable for internal & external mounting, however, powder coated upon request.

Bottom access option is available upon request.

MOUNTING

Suitable for mounting in horizontal applications.

IMPELLER

Impellers high efficiency backward curved centrifugal impeller design.

MOTOR

This product is fitted with EC motors to optimise energy savings and can be controlled via a 0-10V signal providing highest degree of controllability.

AUTO CHANGEOVER PANEL

The fans are fitted with plug and play control unit designed to work with BMS systems as:

- Volt free contact BMS enable
- Volt free contact BMS boost
- BMS fan fault signal
- 0-10 Volt speed control inputs
- Adjustable duty share
- Run on Timer (0-20 minutes)
- Trickle and boost
- PIR enabled boost function

ACCESSORIES - CONTROLLERS

The range of accessories include duct clamps and silencers. A quick reference guide is shown below.



CFC



BDER



0-10V Pot



PIR



Performance Charts

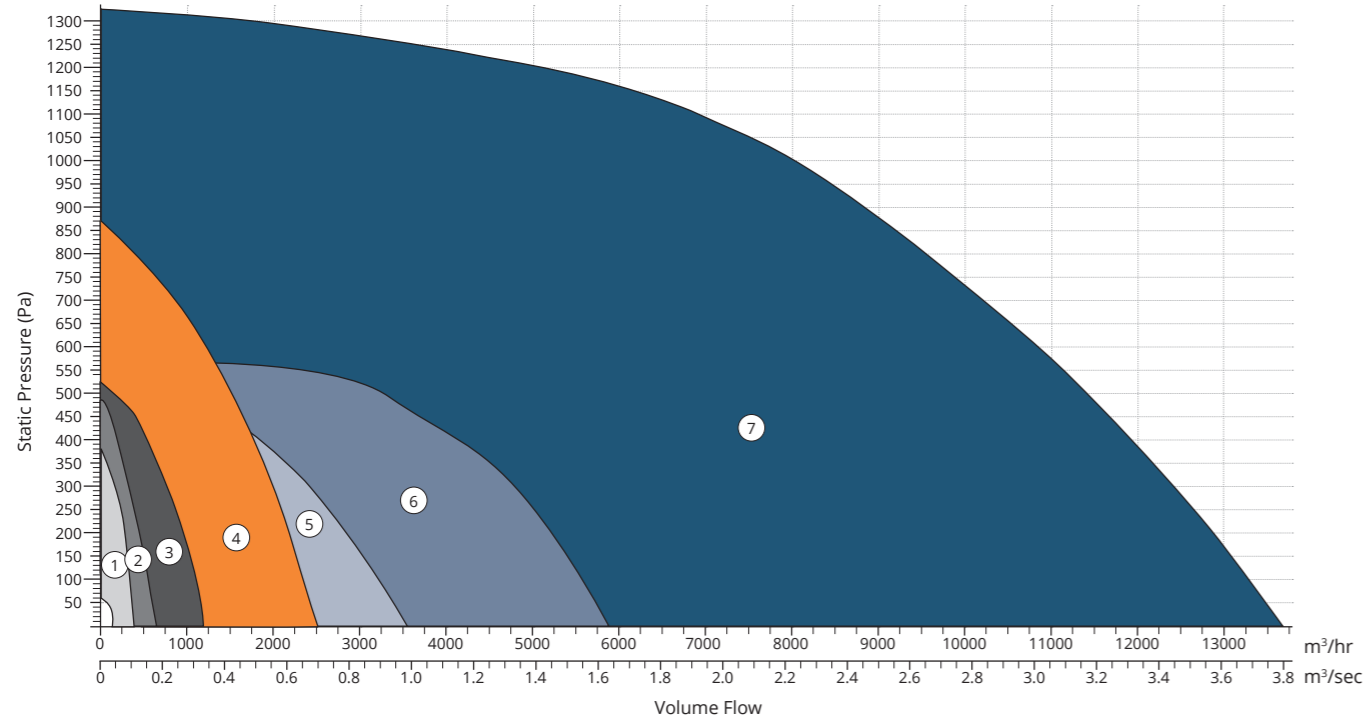

Performance Tables

Ref	Product Code	M³/s @ Pa (Static)													
		0	20	40	60	80	100	120	140	160	180	200	220	240	260
1	Woods EC Twin Box 150	0.04	0.04	0.03	0.01										
2	Woods EC Twin Box 200	0.07	0.06	0.04	0.02										
3	Woods EC Twin Box 250	0.13	0.11	0.09	0.06										
4	Woods EC Twin Box 315	0.28	0.26	0.23	0.21	0.17	0.13	0.07							
5	Woods EC Twin Box 350	0.40	0.35	0.29	0.21	0.13	0.03								
6	Woods EC Twin Box 450	0.66	0.61	0.56	0.48	0.36									
7	Woods EC Twin Box 560	1.56	1.51	1.46	1.41	1.36	1.30	1.23	1.16	1.09	1.00	0.91	0.78	0.57	1.15

Product and Electrical Data

Ref	Product Code	Product Number	Electrical Supply	RPM	Motor (kW)	Full Load Current (A)	Starting Current (A)	Sound level dB(A) (3m)*
1	Woods EC Twin Box 150	EC150112	220-240 V/50 Hz/1 Ph	4320	0.05	0.46	0.46	30
2	Woods EC Twin Box 200	EC200112	220-240 V/50 Hz/1 Ph	3200	0.83	0.75	0.75	31
3	Woods EC Twin Box 250	EC250112	220-240 V/50 Hz/1 Ph	2510	0.17	1.4	1.4	29
4	Woods EC Twin Box 315	EC315112	220-240 V/50 Hz/1 Ph	2360	0.50	2.2	2.2	36
5	Woods EC Twin Box 350	EC350112	220-240 V/50 Hz/1 Ph	1850	0.50	2.2	2.2	36
6	Woods EC Twin Box 450	EC450312	380-420 V/50 Hz/3 Ph	1550	0.95	1.5	1.5	36
7	Woods EC Twin Box 560	EC560312	380-420 V/50 Hz/3 Ph	2480	4.15	6.3	6.3	49

\* Sound power levels are average dB(A) at 3m distance over sphere, under free field conditions and are presented for comparative purposes only. Values shown are those at the mid-point of the performance curve. For ErP efficiency ratings and grades, please refer to our Fan Selector for more information.

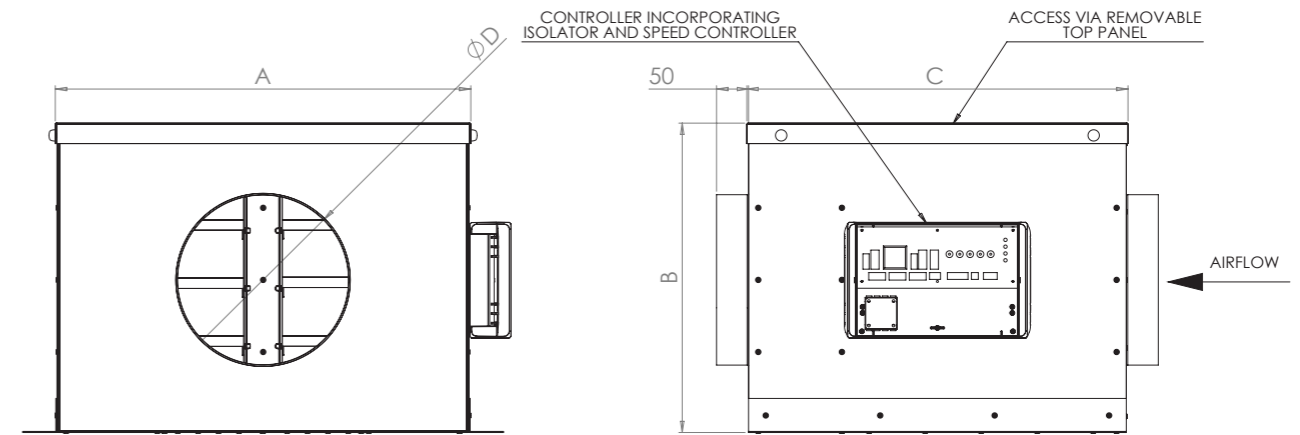

Dimensions

Ref	Product Code	A	B	C	D	E	Weight (kg)
1	Woods EC Twin Box 150	450	250	400	150	180	20
2	Woods EC Twin Box 200	450	350	450	200	210	27
3	Woods EC Twin Box 250	600	450	550	250	240	40
4	Woods EC Twin Box 315	850	450	550	250	240	40
5	Woods EC Twin Box 350	950	550	900	350	295	80
6	Woods EC Twin Box 450	1200	650	1200	450	350	131
7	Woods EC Twin Box 560	1500	830	1500	560	415	222

All dimensions shown in mm

1Phase Wiring Diagram

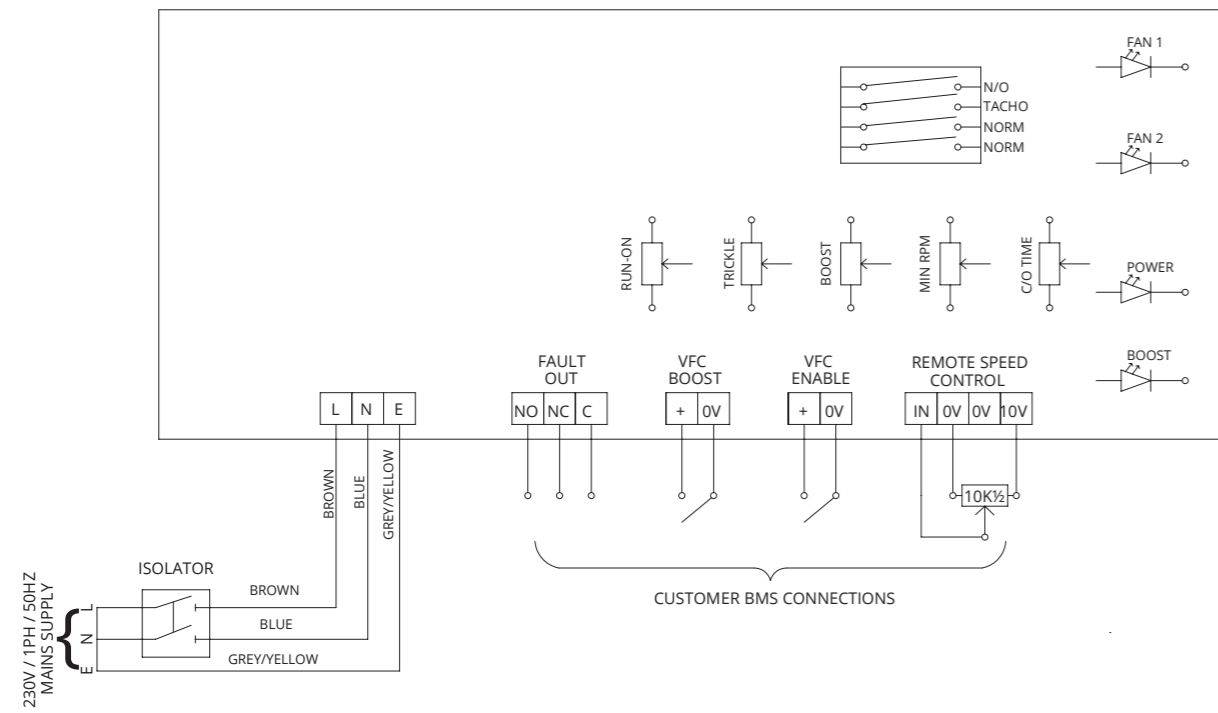

3 Phase Wiring Diagram

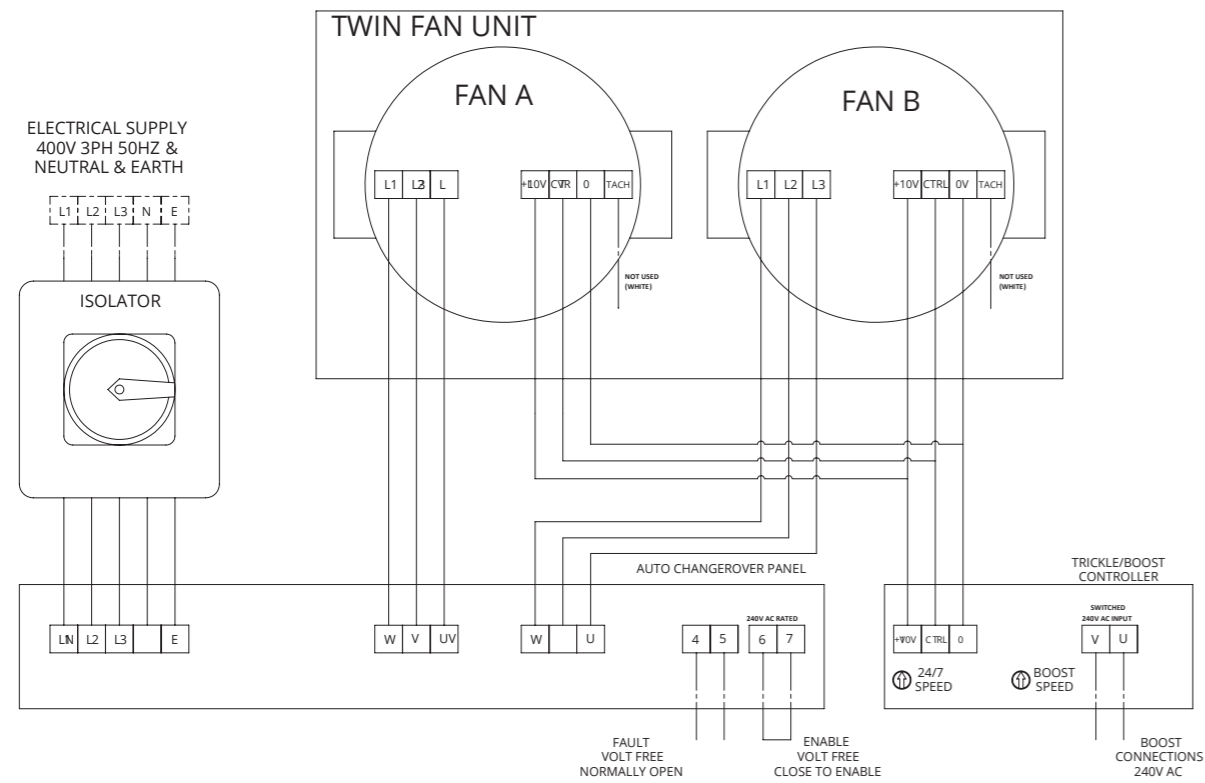



Woods Air Movement Ltd. delivers smart and energy efficient Air Movement and Fire Safety solutions to support every application area. We offer our customers innovative technologies, high quality and outstanding performance supported by more than fifty years of accumulated industry application experience. The widest range of Air Movement and Ventilation products in the market, and strong market presence with over 100 years of experience and manufacturing of products, guarantees that we are always by your side, ready to deliver Excellence in Solutions.

**Contact our friendly sales team today  
for more information**

Call: +44 (0) 1206 222 555

Email: [quotations.woods@flaktgroup.com](mailto:quotations.woods@flaktgroup.com)

[www.woodsairmovement.com](http://www.woodsairmovement.com)

