

## **FIRE SAFETY SOLUTIONS**

Indoor management solutions  
for fire safety and smoke extract





Woods Air Movement is a global leader in air comfort and fire safety. We specialise in the design and manufacture of precision technology to deliver complete, integrated fire safety solutions.

In everything we do, safeguarding the well being of buildings, occupants and owners is always our major priority.

Our collective experience is unrivalled to ensure that we provide you with the perfect solution!

**Within any building's total functionality, one element is paramount: its ability to ensure a safe environment in the event of emergency conditions.**

If such a situation occurs, Life Safety for the occupants, for the emergency services and for the building fabric immediately becomes the priority for the ventilation system.

110 years of air movement knowledge, combined with our in-house expertise and contributions to the development of industry standards, mean we are well placed to respond to new challenges and regulation changes.

Through continuous Research, Development and Innovation we have consistently advanced fan technology to deal with emergency fire conditions.

In a fire emergency, smoke is a potential killer unless it is quickly controlled, it can also hamper the work of emergency services. Whatever the type and function of a building, diligent planning for the fast, effective removal of smoke is an essential provision to ensure personnel safety.

In addition to powered extract fans, we offer a comprehensive range of ventilation components to cover both daily requirements and emergency situations. Our products have been rigorously tested, so fully comply with BS EN 12101-3:2015, which is a key standard, related to components of smoke and heat control systems.

Woods Air Movement can design, supply and install complete systems for smoke extraction to suit the specific needs of each individual building.

Each system typically includes a combination of the following elements:

- Design
- Mechanical ventilation products
- Control systems
- Sensors
- CFD Analysis
- Commissioning
- Maintenance



# We always have the right solutions for your fire safety requirements

## SYSTEM DESIGNS

We offer the greatest value to our clients when we are involved at the design stage. Our in house team of designers and CFD experts are able to optimise the system to ensure the best design based on your specifications using our market leading products.

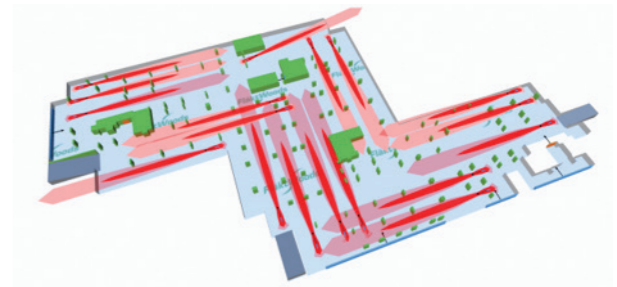

## COMMISSIONING & MAINTENANCE

We have in-house teams and local partners across the world who will ensure that your system is commissioned and maintained successfully and operates as designed in line with local applicable codes and standards.



## SMOKE TESTS

We are able to run hot smoke tests if required which demonstrate the effectiveness of our system designs and products. As one of the pioneers of the jet fans, we have designed and delivered 100's of operational car parks across the world.



## CONTROLS & SENSORS

Localised control solutions are available that your system meets regional and local standards.

## SYSTEMS

We don't just design and manufacture fans. We can provide the complete system and give you a turnkey solution from design to commissioning.

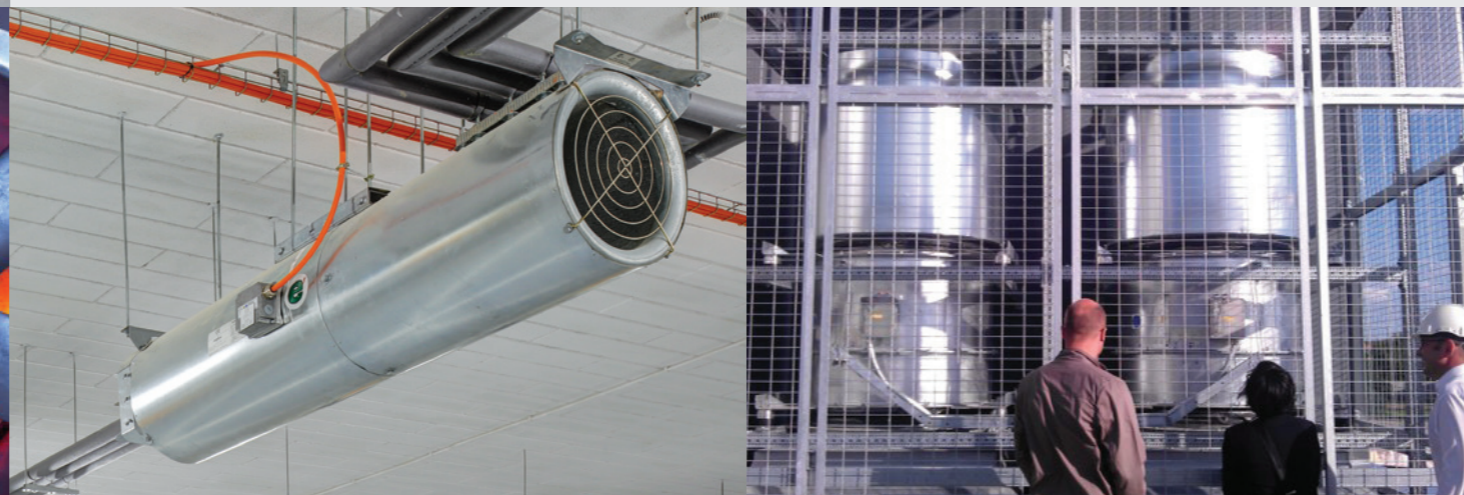

## IN-HOUSE TEST LABORATORY

Our in-house test facilities are some of the most advanced in the world, which have the ability to test in accordance with a wide range of standards to validate Aerodynamic, Acoustic and High Temperatures performance of our fans..

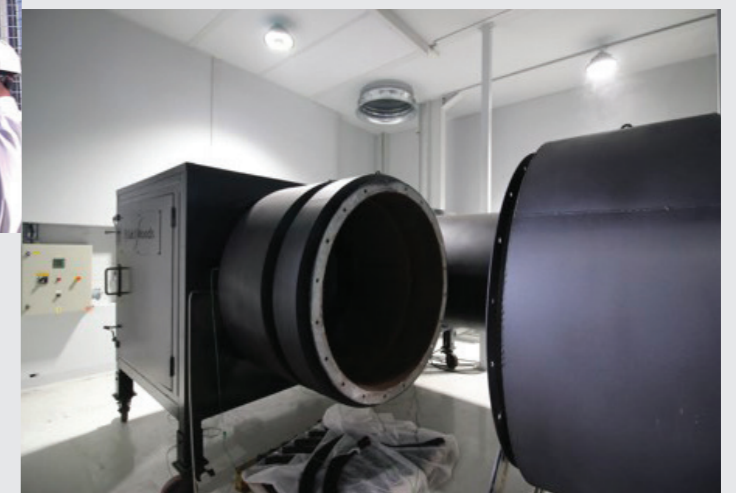

## AXIAL FANS

Woods Air Movement has one of the largest certified ranges of high temperature axial fans in the world. From 315mm to more than 3 metres in diameter and up to F400.

## JET THRUST AND INDUCTION FANS

A wide range of impulse & induction thrust fans are available, including the class leading JTV with ultra high thrust and efficiencies within a limited unit depth.

## INSTALLATION

We can work with your preferred partners to provide a smooth installation or manage the whole process through our own in-house teams and partners.

# AVAILABLE SOLUTIONS FOR WHEN THE HEAT IS ON



We provide a wide range of high temperature fans that are fully certified to EN12101-3:2015 meeting the highest standards.

Woods Air Movement fan types can be suitable for both normal and emergency ventilation conditions.



## JMv(G) AEROFOIL: Energy Efficient Ventilation

### QUICK FACTS

- Up to 84.8% efficiency, FMEG Grade 76
- Operating costs reduced by up to 44.5%
- HT EN12101-3:2015 Certified
- 2, 4, 6 and 8 pole speed options available

### TECHNICAL FACTS

Casing:	Long
Sizes:	315mm to 1400mm #2
Temperature:	-40°C to 50°C F200, F300, Ff300 & F400 (emergency operation)
Volume:	Up to 63.1 m <sup>3</sup> /s #1
Pressure:	Up to 1650 Pa #1
Electrical Supply:	3ph / 50Hz / 60Hz



## JM AEROFOIL: Versatile Ventilation Solutions

### QUICK FACTS

- Bolt on guide vanes deliver higher pressures
- HT EN12101-3:2015 Certified
- 2, 4, 6 and 8 pole speed options available

### TECHNICAL FACTS

Casing:	Long & Short
Sizes*:	315mm to 1600mm
Temperature:	-40°C to 50°C F200, F300, Ff300 & F400 (emergency operation)
Volume:	Up to 51.8 m <sup>3</sup> /s #1
Pressure:	Up to 2400 Pa #1
Electrical Supply:	3ph / 50Hz / 60Hz

\* Larger sizes available on request



## HIGH PRESSURE JM2 AEROFOIL: Versatile Ventilation Solutions

### QUICK FACTS

- Multi-Stage design delivers high pressures
- HT EN12101-3:2015 Certified
- 2 and 4 pole speed options available

### TECHNICAL FACTS

Casing:	Long/Long
Sizes*:	315mm to 1000mm
Temperature:	-40°C to 50°C F200, F300 & F400 (emergency operation)
Volume:	Up to 31 m <sup>3</sup> /s #1
Pressure:	Up to 2500 Pa #1
Electrical Supply:	3ph / 50Hz / 60Hz

\* Larger sizes available on request



NOTES: #1 Maximum air flow volume and pressure shown relates to 50Hz range.  
#2 Maximum fan diameter within our 60Hz range is currently 1000mm.

NOTES: #1 Maximum air flow volume and pressure shown relates to 50Hz range.

# JMv(G) RANGE

## Our JMv(G) High Efficiency fan range extension provides enhanced performance

We designed and launched a revolutionary high efficiency Axial fan range, the "JMv". Our fan design took aerodynamic efficiency beyond the next level, which didn't just meet the Fan Energy related Product Regulation (EU ErP 327/2011) targets, it significantly exceeded them. We can confirm that our original core JMv range has been extended and enhanced by the addition of the 1000mm, 1120mm, 1250mm and 1400mm sizes, which, as they feature new Guide vane technology, are known as "JMv(G)" fans, but as they share a common heritage, they are still part of the JMv family.

Our 1400mm JMv(G) single stage fan develops 30% more airflow than an equivalent JM and 23% more pressure but uses 13% less power. Maximum airflow is 56 m<sup>3</sup>/s, while its maximum pressure development capability is 1500 Pa, so this solution can often replace a two-stage fan. Key benefits of the range include:

- Our JMv(G) range is now available in a diameter range from 315 mm to 1400 mm
- JMv(G) fans deliver Fan and Motor Efficiency Grades (FMEG) up to N77, which far exceeds the current target (N58) and future tier 3 ErP Regulation target (N64)
- JMv(G) Axial fans are suitable for dual mode operation, both normal ventilation and fire mode, when they are design extract hot smoke
- Fans are fully certified in accordance with EN12101-3:2015 for F200, F300 and F400 temperature categories.



### PRODUCT DETAILS

The JMv(G) High Efficiency Axial fan range can deliver air flow rates up to 63.1 m<sup>3</sup>/s and static pressure up to 1650 Pa. Our JMv(G) fans can be mounted into ductwork horizontally or vertically depending on the system configuration and we offer a wide range of accessories, such as mounting feet, anti-vibration mounts, matching flanges and flexible connectors. Fan casings are manufactured from galvanised steel, so have a high level of corrosion resistance, but we can also offer alternative finishes to deliver C3 corrosion resistance. Fan impellers are manufactured from Aluminum, or for specialist applications, from high grade carbon steel.

JMv(G) Axial flow fans are fully certified in accordance with EN12101-3:2015, which allows them to be driven by Frequency Converter (VFD) during a fire event, which provides fire system designers with a greater degree of functional performance.

### FAST FACTS

- Volume flow rate up to 63.1 m<sup>3</sup>/s
- Static pressure up to 1650 Pa
- 3 phase options available
- Suitable for both 50Hz and 60Hz electrical supplies
- Fire rated for 200°C, 300°C and 400°C for a duration of 2 hours
- Continuous operating temperatures up to +50°C as standard (+80°C on request)
- Energy efficient, offers running cost reductions of up to 44.5%
- Low sound levels
- Speed controllable during a Fire Event via our fully compliant HT fan and VSD solution

# AVAILABLE SOLUTIONS OVERVIEW FOR CAR PARKS



Woods fan types can be suitable for both normal and emergency ventilation conditions.

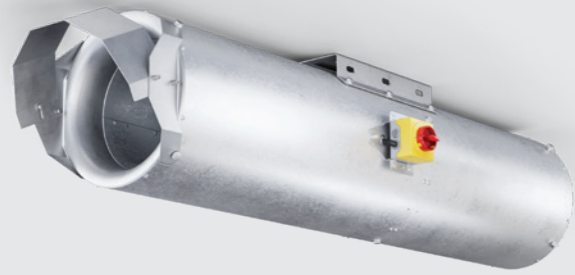

## JTv - SLIMLINE

### QUICK FACTS

- High performance cylindrical silencer
- Compact length
- High efficiency
- Maximum thrust

### TECHNICAL FACTS

Casing:	Cylindrical
Sizes:	315mm to 400mm
Temperature:	F200, F300 & F400
Thrust:	91N (50Hz) & 88N (60Hz)
Electrical Supply:	3ph / 50Hz / 60Hz
Versions:	Uni-directional & Reversible



## JTv - LOW PROFILE

### QUICK FACTS

- Low height for confined spaces
- Low noise levels for a more discreet installation
- Maximum efficiency

### TECHNICAL FACTS

Casing:	Octagonal
Sizes:	315mm to 400mm
Temperature:	F200, F300 & F400
Thrust:	89N (50Hz) & 85N (60Hz)
Electrical Supply:	3ph / 50Hz / 60Hz
Versions:	Uni-directional & Reversible

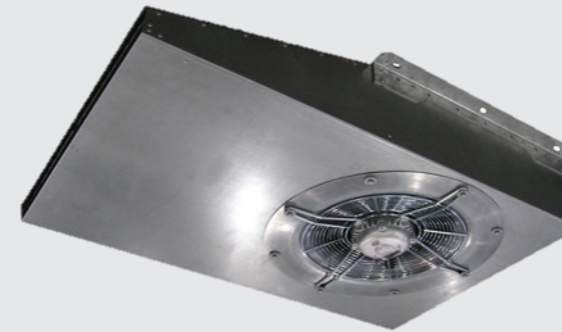

## ITF - SMOKE EXTRACT

### QUICK FACTS

- Ultra Low Profile for confined spaces
- High Thrust

### TECHNICAL FACTS

Casing:	Induction
Temperature*:	F300 & F400
Thrust:	50N, 75N & 100N
Electrical Supply:	3ph / 50Hz / 60Hz
Versions:	Uni-directional

\* Please speak to our sales team to find out which configurations are fully certified.



NOTES: JTv Deflectors are available as an optional accessory.

## HT FAN AND VSD PACKAGED SOLUTION APPLICATIONS

- Allows a Dual mode Axial fan to be speed controlled during normal ventilation mode and Emergency HT mode
- Fan and VSD combination tested and certified by BSRIA and BSI: FULLY complies with EN12101-3:2015 (F300/FF300 & F400)
- Packaged solution uses tried and tested design principles
- Advance VSD design allows multiple duty set points to be defined for the emergency operation mode
- BMS compatibility adds additional control flexibility and high levels of design strategy confidence
- VSD "Fire Mode" ensures that the fan and VSD package performs a smoke extract function for a minimum of 2 hours

**ONE OF THE FIRST FULLY EN12101-3:2015 CERTIFIED Fire Mode Packaged Solutions in the Market**

## EN12101-3: 2015 – STANDARD EVOLUTION

8th April 2017: Smoke and Heat control systems standard changed to include the option to use Frequency Converters during a fire event. This revision, we believe, is a real game changer, as it offers designers more solution possibilities and will contribute significantly to improving building occupant safety

2015 version of this certification standard states 3 basic approaches for using Variable Speed Drives (VSDs) with dual mode High Temperature smoke extraction / Normal Ventilation Axial fans. These are:

- Third Party tested and Certified Fan/VSD range: Only 5% motor de-rate and no need to fit Voltage Waveform filters
- By-pass the VSD during a fire event
- De-rate drive motors by 20% and fit Voltage Waveform filters between VSD and Fan Motor



## THIRD PARTY TESTED AND CERTIFIED FAN AND VSD RANGE

Having successfully completed third-party testing of our core fan range, we are proud to confirm that Woods, together with Danfoss Drives, were one of the first to announce a fully certified EN12101-3: 2015 packaged HT fan and VSD solution in the UK and Europe.

Our VSD HT fan control solution is the most practical, flexible and cost-effective solution as it removes the need for over-sizing fan drive motors and having to fit a Voltage waveform filter.

Reliability of a dual mode fan and matched VSD package is also higher, as fire mode fans are effectively "run tested" every day. Dedicated fire mode fans are typically only tested a few times per year.

To ensure delivery of the best possible customer solution, Woods teamed up with leading VSD manufacturer, Danfoss Drives. Both companies, who together have amassed a total of 150 years' experience within the HVAC industry, are passionate about Quality, Excellence and Fire Safety.

## VARIABLE SPEED DRIVE APPLICATIONS

- Stairwell Pressurisation (Multi-Storey buildings) – Multi-Zone Controls
- Lift Shaft Pressurisation (Multi-Storey buildings) – Multi-Zone Controls
- Smoke Extract Fans (Buildings) – Multi-Zone Controls
- Smoke Extract & Pollution Control Fans (Car Parks) – Multi-Zone Controls
- Tunnel Ventilation, Pollution Control and Smoke control / Extraction



## CERTIFIED RANGE SCOPE – TOP LEVEL ATTRIBUTES

- Any HT Axial flow fan with JM, JMv, JM2, JM2S, JM2SP, JT and JTv impeller variants
- Woods Air Movement approved motor frame size range: 80 to 280 inclusive (Foot/Pad/Flange)
- Maximum motor and VSD rating is 90kW. Larger motors are not currently certified.
- Approved multi-voltage motor electrical supply: 380-420v 50Hz or 440-480v 60Hz (3 phase)
- Maximum Fan speed is not limited to the maximum motor speed, as in many cases, the maximum impeller speed capability is much higher, which delivers a higher performance from a smaller fan.
- HT Categories: 300°C/1 hour, 300°C/2 hours & 400°C/2 hours
- Approved VSD: Danfoss VLT HVAC FC101 and FC102 ranges

## CERTIFICATE UPDATE

Our new and updated EN12101-3:2015 High Temperature fan certification is available on request.

Full Compliance is confirmed by the existence of an associated Technical Annex file: "Fans Driven by PWM frequency converter at ambient and at high temperature A.1.n".

## ADVANTAGES OF USING VSD CONTROL WITH AXIAL FANS

- Precise speed control allows actual design duty to be accurately achieved
- Adaptive speed control (via NOx / CO sensors) delivers optimum pollution control
- Flexibility to adapt fan performance based on evolving system needs
- Energy saving opportunities based on using "on demand" control logic

This defines precise attributes of the tested and approved VSD range.

To confirm full EN12101-3:2015 compliance, HT Fan manufacturers must be able to provide a copy of their Technical Annex file, which supports their test certificate.

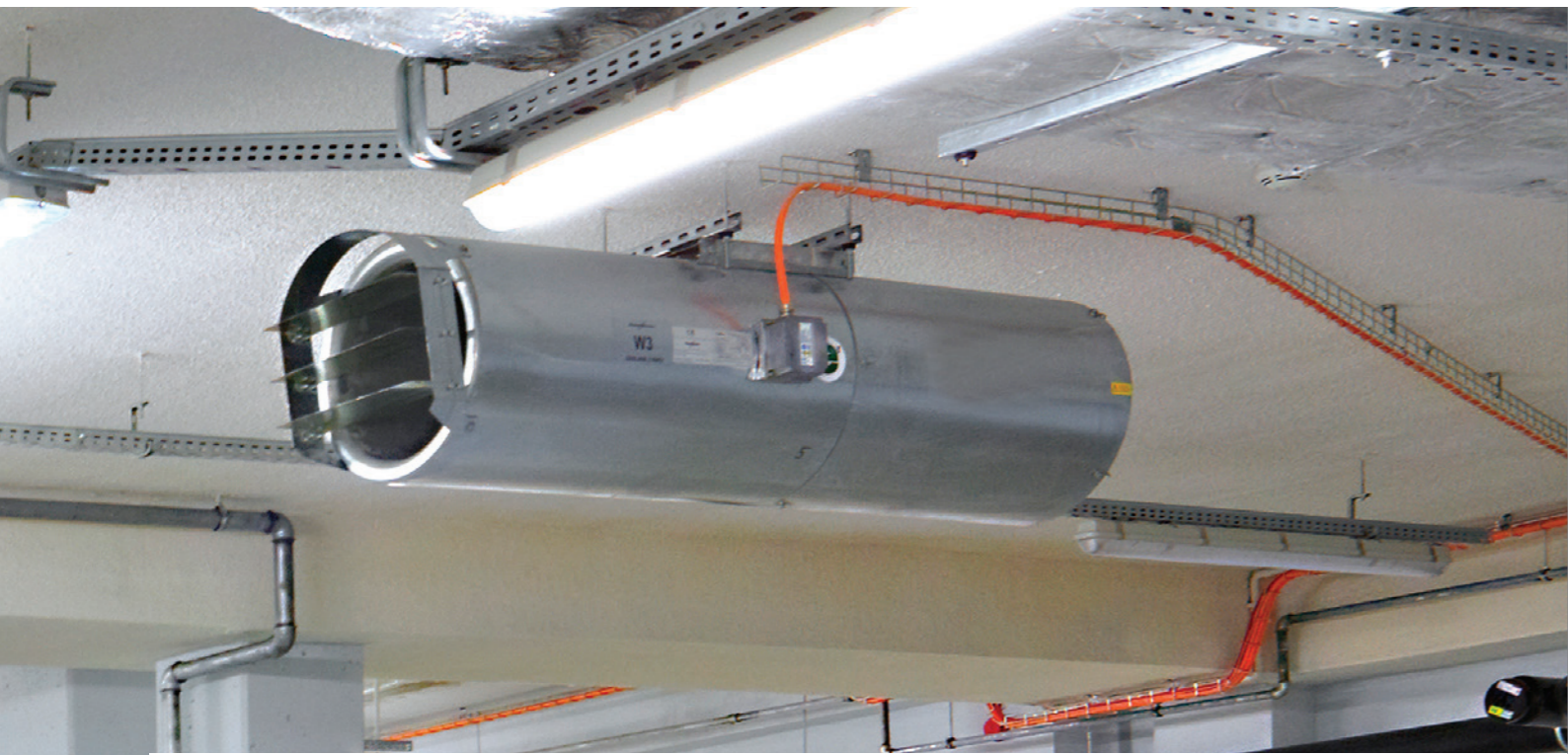

## PROTECTIVE VENTILATION Car Parks

Traditional car park ventilation system designs are based on duct runs with high and low level extract. This design approach typically uses up valuable space and such systems are often costly to install and then operate. Woods can provide a modern alternative solution providing benefit to client and user alike, whilst complying fully with the latest technical requirements and European standards.

### OPERATING ON DEMAND

Unlike traditional system design approaches, with the Woods solutions, single or multiple points of extract are placed strategically, with fitted mounted Jet Fans that may operate independently or in groups.

During day-to-day operation, the level of Carbon Monoxide is constantly measured by gas monitoring sensors throughout the car park level.

Upon detection of increased levels of contaminants, selected Jet Fans are activated to dilute the contaminated air and guide it towards the point of extract.

In the event of a fire, a smoke detection system will cease the day-to-day operation of the car park ventilation system. Depending on the chosen system design approach, the system will be reactive to either clear the smoke or to provide increased visibility to allow improved conditions which leads to more efficient firefighting deployment.

### TAILORED SOLUTIONS USING CFD

Our car park ventilation solutions are designed for the specific structure. Computational Fluid Dynamics (CFD) software, combined with Woods in-house expertise and own fully-researched input data is used to validate the overall performance of the system both in day-to-day and emergency smoke extract mode.

CFD Analysis allows Woods engineers to assess the car park operation with respect to its acceptance criteria; this could be from minimum airflow speed to maximum allowed smoke spread depending on the project need. The engineer can then optimise the position and operation of the system to best suit the criteria. This is supported pre-CFD by detailed calculations to demonstrate system compliance and ensure that the system can achieve the required criteria.

One of the major benefits of the Jet Fan approach is that, by eliminating the extract duct work, the system resistance is substantially reduced allowing smaller motors on the main extract fan units.

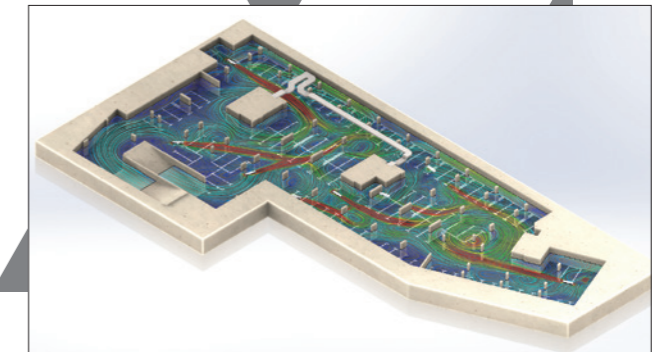
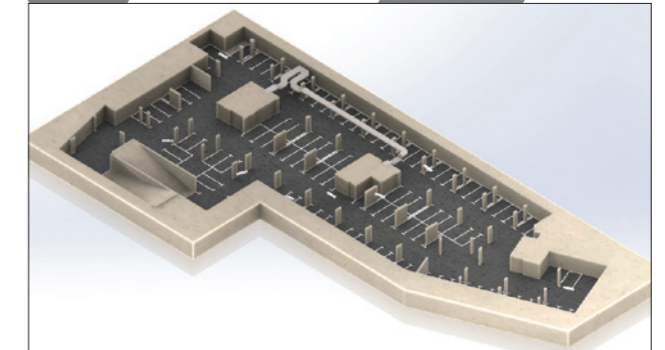
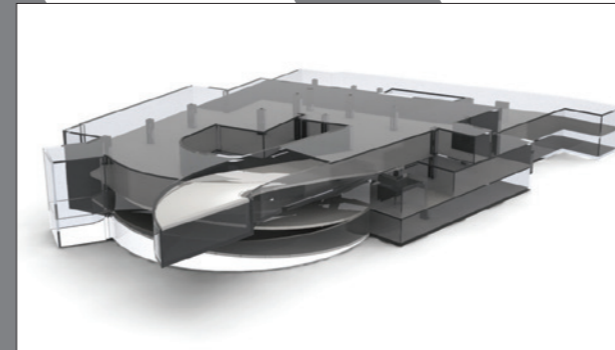

## CFD DESIGN (Computational Fluid Dynamics)

Airflow behaviour is difficult and complicated to predict. Accurate calculation is paramount in order to create an effective car park ventilation system. Woods modelling is backed up with both lab and field tests.

### HOW IT WORKS

Manual calculation methods are limited in their ability to predict proper system performance. This is why Woods offers the possibility to undertake full CFD analysis to customers on their projects.

The CFD software comprises of a solver, which integrates the relevant differential conservation equations (Mass, Linear Momentum Energy and Concentration). The software program solves these algebraic equations for a finite number of iterations until an acceptable level of accuracy has been obtained, allowing accurate car park design.

Woods CFD Engineers are highly trained and experienced, using their knowledge and expertise to design the system to meet the applicable performance requirements.

Design is verified by using industry recognised, highly accurate, CFD modelling software. The system is then adjusted and recalculated if required.

### PROCESS STAGES

1. Client layout drawings and sections are converted into a 3D domain model which is sent to the client for approval.
2. Upon approval the domain model is frozen and detailed calculations commence.
3. The model is initially run with only the main fans operating. This identifies the main bulk airflow paths from the supply to the extract points and any areas of re-circulation within the car park.
4. Thrust Fans are added to the model and positioned to distribute the airflow to all of the areas of the car park, ensuring removal of any stagnant areas of air.
5. A detailed report of the results is produced for each project with appropriate air speed plots, velocity profiles and particle animations.





# Stairwell Fire & Smoke Safety

## SYSTEM DESIGN CONCEPT SUMMARY

- The system provides a dedicated mechanical extraction point on each floor.
- In the event of a fire, where the system is activated on any one floor; an evacuating occupant will exit from the office to the lobby and then into the stairwell.
- The lobby must remain at a negative pressure in relation to the stairwell and adjacent office spaces, ensuring the stairwell is kept smoke free during a fire evacuation.

NB: The lobby is sacrificial, as maintaining the stairwell free from smoke is the primary concern.

There are two operating modes for the system:

### DOOR CLOSED MODE:

- The system operates to maintain a negative pressure in the lobby space relative to the buildings stair cores and accommodation spaces.
- Critically, the accommodation doors must not be pulled open due to this negative pressure, as this would breach the fire compartmentation of the lobby.

### DOOR OPEN MODE:

- When either the accommodation or stairwell door opens, the fan speed (and delivered duty) increases to maintain the negative pressure within the lobby ensuring that the stairwell remains free from smoke, with the relevant door(s) open.

As the built environment continues to require ever taller buildings, so does the need for more robust and intelligent fire protection systems capable of ensuring the safe evacuation of these elevated structures. Woods Air Movement is actively involved in supporting this development with our range of fully EN 12101-3:2015 certified Smoke Extract Axial fan range, which are used either within our own roof, wall or duct mounted smoke extract or pressurisation solutions or those offered by our local partners, who also often offer turnkey solutions, from design to installation.

The most popular design concept is to exhaust smoke from stairwell lobbies within a building, via appropriately sized fire rated extract shafts. This solution uses two high temperature Axial flow fans, which our installers or local partners mount in series to provide a duty and standby function which offers a higher degree of protection. This assembly is positioned at the top of the extract shaft at roof level.

Importantly and necessary for correct operation of the system, replacement fresh air enters the building via a ventilator installed at the top of the stairwell. Pressure sensors monitor the input air to ensure that the forces on lobby doors do not exceed the prescribed limit of 100N. This enables the system to maintain a negative pressure in relation to the stairwell, ensuring that escape routes are kept free from smoke, which minimises the potential for smoke inhalation by escaping occupants.

Critically and most importantly, the system operates automatically via smoke detection and includes pressure sensing equipment which modulates the fresh air input fan speed, ensuring that the forces on lobby doors do not exceed acceptable levels.

Where the pressurisation solution requires to be duct mounted, our SMPA product provides this installation option.

In addition to the above, fire safety solutions also include our Hatch (SMHA and SMWH) roof and wall mounted smoke extract units and feature a powered hatch that automatically opens during a fire event. Our roof mounted SMIA "Hatch" product not only provides a Smoke Extract function but can be reversed to provide a fresh air input mode as well. Our speed controllable HTC Smoke Extract units are also designed for roof installation.

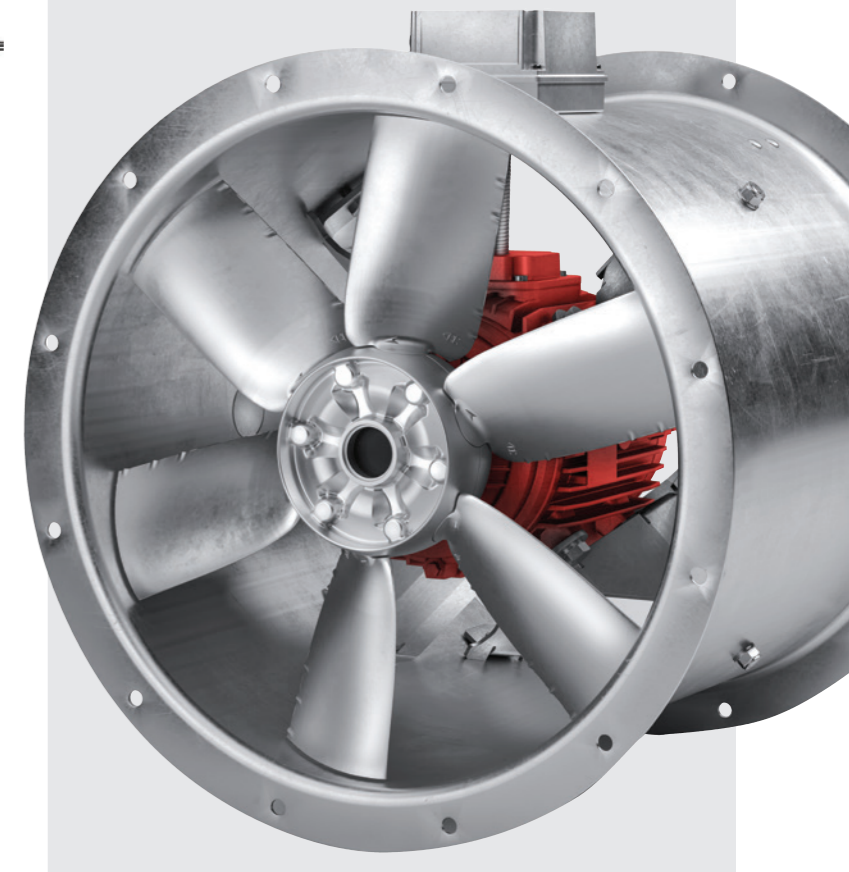
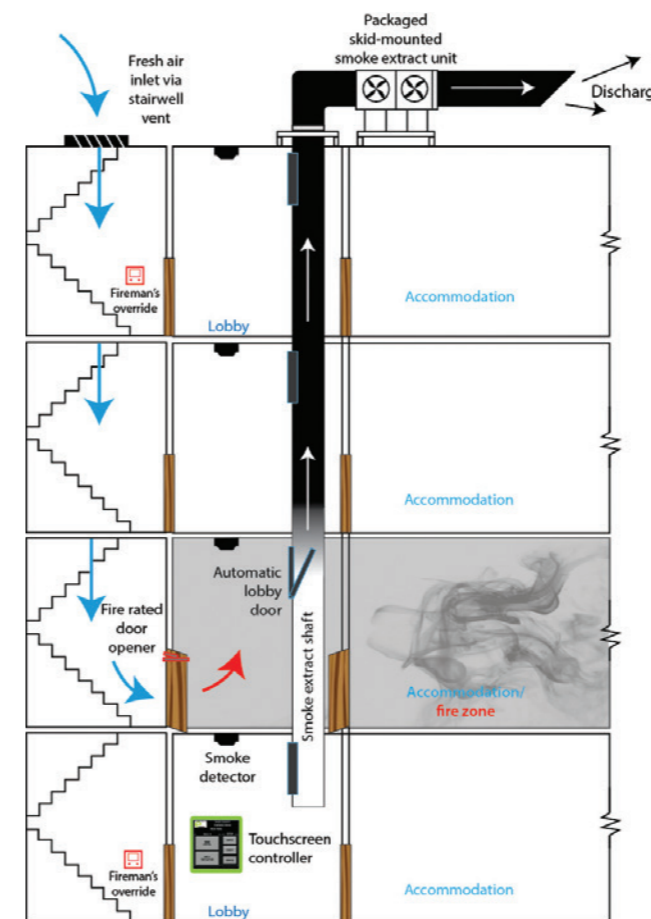

# OTHER SOLUTIONS WE CAN PROVIDE



## Road Tunnels



### Road tunnels require ventilation to remove pollution and in case of a fire for the control of smoke.

Longitudinal ventilation is used where possible, as it gives the lowest installation and operating cost. The most common method is to use Jetfoil fans where the relatively high velocity discharge induces a flow of air through the tunnel. As the jet from the fan diffuses, it transfers energy to the tunnel airflow and creates an increase in static pressure, which causes air to flow as in any conventional system.

For free flowing traffic in one way tunnels the traffic induced airflow is normally sufficient to ventilate the tunnel even if the tunnel is designed with a fully or semi transverse system.

Large axial flow fans are used for transverse and semi transverse systems where the air is supplied or extracted through ducts from plant rooms. Normally several fans are used in parallel to provide steps in volume flow. Frequently the fans are VFD controlled to provide additional steps in ventilation, a lower operating cost at low levels of flow and low noise levels for night time operation. Often the fans are 100% reversible so that supply fans can also extract. To clear smoke from one side of a fire, reversible fans may be used with the duct system to create a longitudinal flow along the tunnel.

There can also be occasions where a longitudinal system using Jetfoils is justified in addition to a transverse system as the operating cost at low ventilation rates is much less.

To avoid pollution at the openings of the tunnel, large fans may be used to capture the tunnel airflow and discharge it at a high level.

## Metro & Underground Railways

### Ventilation is required to remove the heat generated by the trains and other electrical equipment.

Virtually all of the electrical power consumed degenerates into heat which is removed by a combination of natural and powered ventilation. During free running conditions the piston effect of the trains may be sufficient for ventilation and natural ventilation may maintain this condition even when the trains are not operating. However, when the system becomes congested and trains are running at short intervals or, in the case of an incident, are stationary with minimum spacing, forced ventilation becomes necessary.

The amount of heat generated by trains in rapid transit systems of high density usage is the largest single factor in determining the mass flow of air required to maintain a stable air temperature. However the risk of fire must also be taken into account. Frequently VFD controlled fans are used with low speed for heat removal and high speed for fire smoke control.

Longitudinal ventilation along the tunnel is common using 100% reversible fans. For an enclosed system large fans connected to atmosphere would be used in a push-pull configuration. If the system is not enclosed jetfoils can be used to induce the required airflow along the tunnel to and from atmosphere. Smoke is directed in the most favorable direction depending on the position of a fire in the train or tunnel. Fans are rated up to 400°C for 2 hours. Air movement in the stations follows normal ventilation practice as far as possible. For smoke control, supply and extract fans are used, reversible if a longitudinal system is being used. Smoke curtains can be used to create smoke reservoirs.





## FIRE SAFETY

In the event of a fire; large axials and jet fans, or a combination of the two can be used clear smoke from the tunnel to aid in the safe evacuation of the tunnel. The controlling the direction and flow of smoke the ventilation system can also allow firefighters safe access to the fire in order to extinguish it.

There are three main system types used for pollution control and fire safety:



# LARGE AXIAL FANS

### Fully Transverse System

A fully transverse system supplies fresh air from a low level, normally from a duct underneath the roadway. The hot, polluted air rises and is extracted at a high level normally through a ducted system above the roadway.

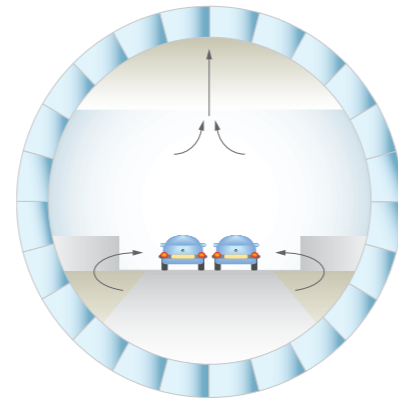

### Semi-Transverse System

This system is similar to the fully transverse system in the supply and extraction of air and is used for long, congested two-way tunnels. Semi-transverse systems rely on longitudinal air movement along the tunnel and require a higher ventilation rate.

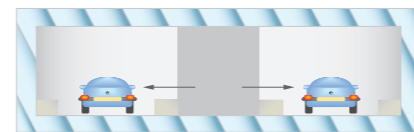

### Longitudinal Ventilation Systems

The simplest solution for tunnels as air movement is created along the length of the tunnel by large fans, jet fans or a combination of the two. The air can enter at one portal and leave at another, or be supplied or extracted at points within the tunnel.

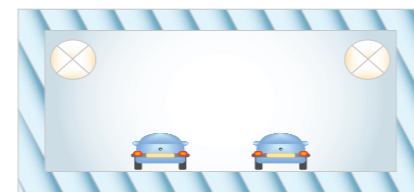

## LARGE JM High Temperature Fans

- Size range 1250mm to 3550mm
- Guaranteed performance to ISO 5801
- Unidirectional or Truly Reversible blade
- Higher pressure twin impeller and 2 stage fans are available
- High Temperature certification for 200°C and 300°C categories up to 710 kW, and 400°C up to 1000 kW
- Static pressures up to 4000 Pa and volume flow up to 250 m³/s
- We can test fans up to a diameter of 3550mm, running at 1500 rpm, with a maximum rated motor power of 1 MW
- All cast rotating impeller components are examined by X-ray to ensure reliability in service
- IEC motors certified to EN 12101-3 and ISO 21927-3
- Steel parts hot dip galvanised or hot Zinc Sprayed (except hub)
- Manufacturer registered and assessed in accordance with BS EN ISO 9001
- Paint finish optional
- Accessories: guards, condition monitoring, anti vibration mounts, flexible connectors, bellmouth/ coned entries, diffusers, transition pieces, silencers, dampers, starters and controls

# JETFOIL FANS

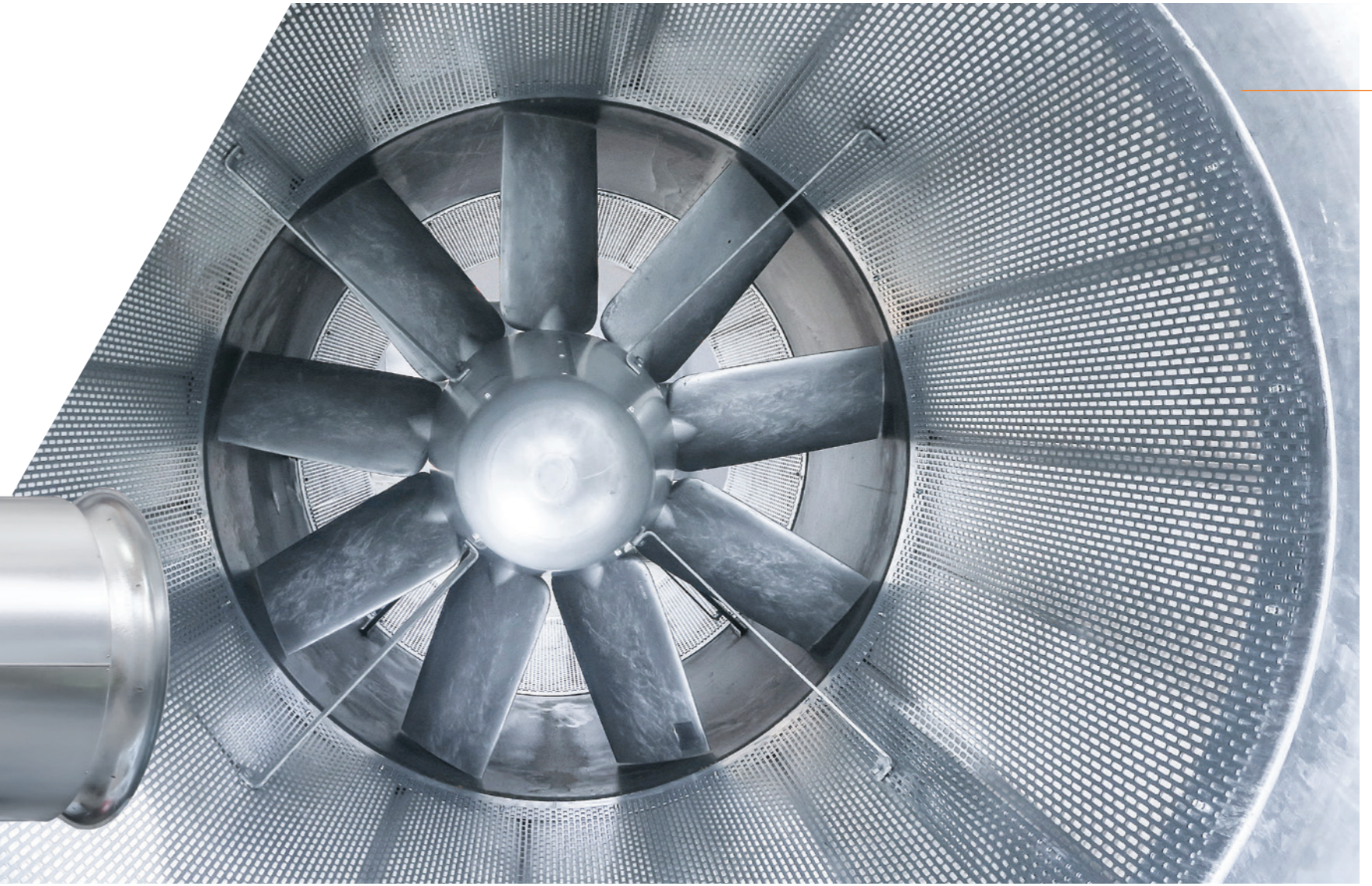

Our expertise in tunnel ventilation applications covers road and rail tunnels, metros, tunnel construction and wind tunnels. Woods products have been successfully used in underground projects throughout the world and our Jetfoil product range is unrivalled in its technology, innovation, efficiency and thrust.

## JETFOIL FANS

- $\varnothing$ 560 -  $\varnothing$ 1600 mm
- Thrust up to 3500N
- $\varnothing$ 800 mm up to 1800 rpm,  $\varnothing$ 1250 mm up to 1800 rpm and  $\varnothing$ 1600 mm up to 1200 rpm
- Fully adjustable die cast aluminium impellers in uni-directional and truly reversible configurations; and 100% X-ray of all cast impeller components
- Mild steel casing - hot dipped galvanised after manufacture, painted or all stainless steel construction
- Silencers fitted where required
- Motor protection IP55 minimum
- Motors certified to EN 12101-3
- Emergency ventilation options up to 400°C/2 hours
- Truly reversible fans provide approximately equal thrust and airflow in forward and reverse directions
- Noise Levels: acoustic analysis and attenuators to ensure the fans are in accordance with environmental requirements and local regulations is available
- Applications; longitudinal ventilation of road tunnels, mine ventilation, emergency ventilation - smoke control, hangar/large area ventilation

# EN 12101-3 AND ISO 21927-3 HT CERTIFICATION

Emergency, High Temperature Smoke Extract Fans fall within the scope of the EU Construction Products Regulation.

The implementation of the Construction Products Regulation and the publication of the product specific standard, EN 12101-3 have made it a mandatory requirement for smoke control fans sold in the European Union to carry a CE Mark from April 1st 2005.

The CE mark may only be affixed after successful completion of testing, auditing of factory production control and issue of a certificate by accredited independent authorities.

The procedure is intended to prevent fans failures during an emergency smoke situation, where a fan failure can ultimately lead to loss of life.

Woods fully endorse the concept that, in such a safety critical application, only fully verified and certified products should be specified. As such all JM fans are tested and certified.

The Woods JM range was successfully tested and are certified to EN 12101-3 and ISO 21927-3 by a third party; however, because of ISO 21927-3 applies globally, it provides specifications against which powered smoke and heat exhaust ventilators can be evaluated and certified outside EU member states.

Woods worked with the certifying authorities to build and certify a high temperature facility capable of testing fans up to 3.5 metres diameter at up to 400°C.

This investment resulted in Woods being able to offer a British Standards Institution Certified, CE marked JM HT product including 300°C/2 hours 400°C/2 hours ranges, in diameter starting at 1400mm up to a maximum of 2800mm at relevant time/temperature categories.

This investment also resulted in Woods being able to offer a British Standards Institution Certified, CE marked Jet Fan product for use at 400°C/2 hours from 560mm to 1600mm, together with a comprehensive range of approved accessories.

Woods have enhanced their position as the foremost provider of specialist products for emergency high temperature smoke control by becoming the first fan manufacturer in the world to be able to apply CE marking to these safety critical products, ensuring that Woods has one of the most comprehensive range of products available in the World.

It is also believed that Woods is now the only manufacturer to have successfully tested a 2.24 metre diameter fan, running at 1500 rpm with a 1MW motor.



2797



2797 - CPR - 474778

EN 12101-3: 2015  
Powered smoke and heat exhaust ventilators for use in Construction Works  
Resistance to Fire Class F400 400°C for 2 hours  
Motor rating Class F/Class H



**Certificate of Constancy of Performance**

This is to certify that: **Flakt Woods Limited**  
Astral Way  
Colchester  
CO4 5ZD  
United Kingdom

Holds Certificate Number: **2797 CPR 474878**

In respect of:  
**EN 12101-3:2015 - Smoke and heat control systems. Specification for powered smoke and heat exhaust ventilators.**

In compliance with Regulation 305/2011/EU of the European Parliament and of the Council of 9 March 2011 (the Construction Products Regulation or CPR), this certificate applies to the above construction product. This certificate attests that all the provisions concerning the assessment and verification of constancy of performance described in Annex ZA of the above standard(s) under system 1 for the performance set out in this certificate are applied and that the factory production control conducted by the manufacturer is assessed to ensure the constancy of performance of the construction product(s). This certificate was first issued on the date below and will remain valid as long as neither the harmonised standard, the construction product, the AVCP methods, nor the manufacturing conditions in the plant are modified significantly, unless suspended or withdrawn by the notified product certification body.

For and on behalf of BSI, a notified Body for the above Regulation (Notified Body Number: 2797);  
Previous Notified Body: 002 0006  
First Issued: 2004-09-07

  
Dr. Dave Hagerlaars, Managing Director

Latest Issue: 2020-02-10

Page: 1 of 26



...making excellence a habit™

This certificate has been issued for and remains the property of BSI Group The Netherlands B.V., Jans H. Reijnenplein 9, 3008 GP Amsterdam, The Netherlands and should be returned immediately upon request.  
To check its validity telephone +31 20 740070, an electronic certificate can be substantiated [online](#).

## WE HAVE THE LARGEST CERTIFIED HIGH TEMPERATURE RANGE IN THE WORLD!



Our wide range of fans can be installed in various applications.





Woods Air Movement delivers smart and energy efficient Air Movement and Fire Safety solutions to support every application area. We offer our customers innovative technologies, high quality and outstanding performance. The widest range of Air Movement and Ventilation products in the market, and strong market presence with over 100 years of experience and manufacturing of products, guarantees that we are always by your side, ready to deliver Excellence in Solutions.

**Contact our friendly sales team today  
for more information**

Call: +44 (0) 1206 222 555

Email: [quotations.woods@flaktgroup.com](mailto:quotations.woods@flaktgroup.com)

[www.woodsairmovement.com](http://www.woodsairmovement.com)

