



CAR PARK JET-THRUST FANS

Operation & maintenance manual
HT F200, F300, F400



PART NO. 419742 US

CONTENTS

	PAGE
1 SAFETY	3
2 INTRODUCTION AND PURPOSE	3
3 STORAGE	4
3.1 PRODUCT CARE	4
3.2 UNPACKING	4
3.3 LONG TERM STORAGE	4
4 MECHANICAL INSTALLATION	4
4.1 INITIAL INSPECTION	5
4.2 HANDLING	5
4.3 MOUNTING & ALIGNMENT	5
5 ELECTRICAL INSTALLATION & OPERATION	5
5.1 CONNECTION	6
5.2 FUSES & WIRING	6
5.3 SPEED CONTROL	6
5.4 OVERHEAT PROTECTION	7
5.5 EMERGENCY-USE FANS	7
5.6 SWITCH-ON	7
6 MAINTENANCE	7
7 INFREQUENT USE	9
8 OVERHAUL / EXTENDED MAINTENANCE	9
9 FAULT-FINDING	9
9.1 ELECTRICAL	9
9.2 MECHANICAL	9
10 DISPOSAL	10
11 CONNECTION DIAGRAMS	11
3 PHASE, TWO SPEED MOTOR, PILLAR BLOCK TERMINALS	11
3 PHASE MOTOR WITH ISOLATOR FITTED	11
POLE CHANGE MOTOR	11
12 TERMINAL	12
13 INSTALLATION	13
14 FURTHER DOCUMENTATION.....	13

1. SAFETY

Warning and safety information relevant to specific operations are contained within each section. The following warning or advice categories are used:



DANGER! Failure to follow these instructions may result in serious injury or death to the user in addition to serious damage to the equipment.



WARNING! Failure to follow these instructions may result in minor injury or damage to the equipment.



CAUTION! Failure to follow these instructions may result in malfunction or damage to the equipment.

Only approved, qualified personnel familiar with the assessment of hazards and risks associated with fans, and with the use of tools and test equipment required to service such fans, should install, operate and maintain the product.

If the installer or user is unable to understand the information in this manual, or has any doubt that safe and reliable installation, operation and maintenance of the equipment can be assured, Woods Air Movement or their representative should be contacted for advice.

Warnings and safety information relevant to specific operations are contained at the start of the sections to which they apply.



DANGER!

This product contains rotating parts and electrical connections that can be a danger and cause injury.

It is of paramount importance for any fan that is required to function in emergency conditions, that the installer and user follow all relevant instructions in this leaflet, as well as those contained in the general Instruction Leaflet supplied with this product.

To ensure that the fan will operate as intended, if an emergency results in an abnormal high air temperature, the user must:

- a) Ensure that the electrical system has been designed and installed in a manner that is associated with the specified emergency conditions of temperature and duration.
- b) Institute a regular, verifiable maintenance procedure that takes into account the requirements and recommendations in this leaflet, in and recommendations in this leaflet, including re-lubrication as specified and, after an appropriate number of years, a complete re-fit.

2. INTRODUCTION AND PURPOSE

Woods Air Movement car park ventilation system uniquely positions Jet Thrust fans and extract fans to transport contaminated air to extract points, eliminating the need for expensive distribution ductwork within the car park.

The fan assembly is manufactured and aligned specifically to fulfil the requirement of the installation for which it was designed. No deviation from the original requirement should be implemented without referring to Woods Air Movement head office in Colchester. Any queries regarding safety or operating problems should be referred to the local Woods Air Movement office, sales centre or representative, together with full fan/motor nameplate details. Should a fan failure occur whilst the product is under warranty, the Woods Air Movement Service Centre in Colchester should be contacted before any repair work is undertaken.

A separate installation and maintenance document for the motor is supplied with the fan.

3. STORAGE

3.1 PRODUCT CARE

If the fan assembly is to be stored, check immediately on receipt that it is as ordered, and that it has not been damaged in transit. Where the fan is delivered in a crate (or similar), the crate should be considered as a protective device only. The crate must not have equipment stacked on it, and it must not be stacked on other equipment. The crate structure must not be used as a lifting aid unless otherwise indicated. A fork-lift truck or similar should be used for moving the crate. The fan should be stored in a safe, clean, dry, vibration free, location. If such storage conditions are not available the motor anti-condensation heater (if fitted), should be connected to an appropriate electrical power supply to prevent motor condensation forming. The fan should be stored in an appropriate container.

A regular monthly rapid spin of the impeller is recommended to prevent grease hardening and possible brinelling of the bearings. The impeller should not be in the same angular position after rotation.



WARNING!

When fan assemblies are retained in storage, access by unauthorised persons must be prevented with the use of guards, barriers or secure premises such that fan impellers that may be rotating (windmilling) do not present a hazard.

3.2 UNPACKING

When dismantling the crate to gain access to the fan assembly, care should be taken to avoid injury from sharp edges, nails, staples, splinters, etc. Prior to installation, remove any additional packing feet that will not be used for the mounting of the fan.

3.3 LONG TERM STORAGE

If the fan is to be stored for 12 months or more, an inspection by Woods Air Movement Service Centre in Colchester before commissioning is advised.

4. MECHANICAL INSTALLATION



DANGER!

It is recommended that suitable safety guards form part of the installation wherever necessary. If access to an unguarded part of the fan is possible; an additional guard must be fitted. Advice on safety guards is available from Woods Air Movement.



WARNING!

Where the fan assembly is delivered packaged, the packaging must be considered as a protective device only and must not be used as a lifting aid unless otherwise indicated.



WARNING!

All lifting aids and lifting points used during installation should be adequately certified to carry the weight of the equipment being lifted. During lifting, all personnel must be clear of the area below the fan.



CAUTION!

Before entering the area, ensure that the environment is safe to effectively work in, that any fumes, dust, toxic emissions, and environmental hazards etc., have been removed and that the fan blades are not likely to windmill.



WARNING!!

Always wear appropriate protective clothing (including harnesses, hard hats, eye protectors, gloves, boots and ear defenders) when working in the vicinity of the fan assembly.



CAUTION!

Care must be taken to avoid damage to the inner perforated skin of the silencers when working on the fan.

4.1 INITIAL INSPECTION



NOTE!

Before installing the fan assembly, check that it has not been damaged in transit/storage (bent flanges/ mounting feet, deformed duct/silencer, damaged motor/guards/impeller etc). Ensure that the impeller rotates freely at the correct pitch angle, and that the fan and motor nameplate data comply with the requirement of its use. If the fan assembly has been stored, the resistance of the motor windings to earth should be measured (at 500V d.c). If the reading is less than ten megohms (10 MΩ) the motor should be dried in a warm airflow and rechecked before it is switched on.

4.2 HANDLING

The fan can be heavy (between 50 and 150kg depending on fan/motor size and ancillaries), and sometimes unwieldy (centre of gravity not central), and should therefore be lifted slowly to prevent damage and distortion. Proper precautions must be taken and certified lifting aids used, to ensure the fan is well supported and stable before lifting into position. The fan must be installed, such that it is squarely positioned in accordance with the airflow direction requested when the fan was ordered. Packing shims can be used to ensure the fan is squarely in place. An airflow indication arrow is shown on the fan nameplate. Adequate unobstructed room must be allowed around the fan for safe inspection and future maintenance. The environment must be safe for both the fan and for personnel, with emergency escape procedures in place should they be necessary. Care must be taken to ensure that during extremes of wet and windy weather any ingress of water through the fan will not reach sensitive or hazardous areas.

4.3 MOUNTING & ALIGNMENT

The thrust of the fan is unlikely to give excessive load or movement to the mountings but its effect on any support apparatus must be considered.

Cylindrical fans must be mounted directly to the ceiling slab, or on suitable drop rods. Use the two in-board feet fastened to the fan casing, and the two out-board feet fastened to the ends of the silencers.

Low-profile rectangular and octagonal fans should be mounted directly to the ceiling mounting slab or suitable mounting frame using the four fan mounting feet.

5. ELECTRICAL INSTALLATION & OPERATION



DANGER!

The fan assembly contains rotating parts and electrical connections that can be a danger and cause injury. If there is any doubt that a safe and reliable electrical installation of the fan can be assured; Woods Air Movement or their representative should be contacted for advice.



WARNING!

If the fan assembly is designed for high-temperature emergency use, it is imperative that the wiring used is high temperature rated and that all switches and controls are capable of being overridden during emergency operation.



CAUTION!

If the fan stops due to an overheat situation, the overheat protection thermostats (if fitted - see section 5.4). May reset as the temperature cools and automatically restart the fan if power is still applied.



WARNING!

Always wear appropriate protective clothing (including harnesses, hard hats, eye protectors, boots, gloves and ear defenders) when working in the vicinity of the fan assembly.

5.1 CONNECTION

The fan assembly is fitted with either a terminal box or isolator on the fan duct. The electrical mains supply to the fan assembly should be connected by an appropriately qualified electrician. Any unused entry points into the terminal box or isolator must be sealed. Connection details are provided with the fan assembly and are further detailed at the back of this manual, along with the correct assembly sequence of terminal box parts and the necessary torque settings. It is essential that no lock-washers or nuts are placed between the motor lead eyelet, connecting link or customer's supply lead eyelet (when fitted). It is good practice to incorporate an isolation switch in the system if not specified with the fan. The switch allows safe control and provides a means of safely isolating the fan (until a controlled restart is made). Isolators also protect personnel during a fault situation, maintenance or power supply failure/fluctuation. Electrical isolation can be achieved remotely using the car park control panel. A suitable earth must also be connected.

5.2 FUSES & WIRING

Fuses and wiring in the fan electrical control circuit must be sufficiently rated to carry the fan starting current as indicated on the motor nameplate. Fuses should be regarded as only protecting the wiring against the effects of short circuits or earth faults; they are not suitable for overload protection. To provide full protection for the motor, a control panel with overload protectors should be used. Overload protectors should be rated 15% above the motor full load current indicated on the motor rating label. High temperature applications require special fire-resistant cable to be used between the main supply, starter controls and the fan. The mains supply should be from a guaranteed or separately maintained source to enable the fan to continue running under emergency conditions.

5.3 SPEED CONTROL

Speed controllers should not be used without prior agreement with Woods Air Movement.

If frequency inverters are intended to be used it is recommended that Woods Air Movements are contacted for advice prior to fitting.

5.4 OVERHEAT PROTECTION

Motor overheat protection (if fitted) can be fitted on all motors. Overheat protection is achieved by the use of either thermostats or thermistors. The protection devices are wired in either of the following two ways:

- On motors with a full load current of **up to and including 6.3A**: Thermostats are wired in series with the motor winding; they operate by opening and closing with temperature to automatically open the winding circuit and stop the fan in an overheat situation (see Section 5 Warning). On cooling, the motor will automatically re-start. Thermistors are wired to separate terminals (S -S) within the terminal box; they operate by changing their resistive value with temperature and must be wired to control the motor start contactor via a suitable relay.
- On motors with a full load current **above 6.3A**: Thermostats are wired to separate terminals (K - K) within the terminal box; they operate by opening and closing with temperature and must be wired to directly control the motor start contactor. Thermistors are wired to separate terminals (S -S) within the terminal box; they operate by changing their resistive value with temperature and must be wired to control the motor start contactor via a suitable relay.



NOTE!

Note that when the motor cools the thermostat will reset; the motor however must not be able to start until the motor start contactor is manually reset

5.5 EMERGENCY-USE FANS

Where the fan assembly is designed for emergency-use smoke-extraction at high temperature, the temperature/time capability will be shown on a special label adjacent to the main nameplate. An automatic control system, or a clearly marked remotely sited emergency-use switch, must be fitted to override all other switches and controls and immediately switch on the fan in the case of such an emergency situation.

High temperature cable must be used between the remote switch and the fan, and the electrical supply must be from a guaranteed or separately maintained source to enable the unit to continue running during the emergency condition. After such an emergency the fan must be removed, refurbished or safely disposed of (see section 10), and replaced as necessary.

5.6 SWITCH-ON

Before switching on, confirm that the electrical supply is fully compliant with the requirement of the motor as detailed on the motor nameplate, Ensure that the fan is correctly installed, all component parts and fixings are secure, safety guards are in place and no loose articles are present in the vicinity.

Immediately after switch-on check the assembly for smooth, low-vibration running and check that the current consumption is within the full load current specified on the nameplate. A trial connection of the three-phase supply should be made to check that the fan rotates in the required direction. If the rotation is incorrect, interchange any two phases of the incoming supply at the motor terminal block. The fan must not be switched on and off in a manner that could cause overheating of the motor or its wiring, for further details see motor maintenance document.

6. MAINTENANCE



DANGER!

No maintenance work should be attempted before switching off and completely isolating the fan assembly, its anti-condensation heater (if fitted), and its controls, from all electrical supplies and allowing the rotating parts of the fan to come to rest.



WARNING!

Before entering the area, ensure that all fumes, dust, toxic emission, heat etc., have dispersed from the local environment and the fan blades are not likely to windmill.



WARNING!

All lifting aids used during maintenance, and all lifting points utilised, should be adequately certified to carry the weight of the equipment being lifted.



WARNING!

Always wear appropriate protective clothing (including hard hats, eye protectors and ear defenders) when working in the vicinity of the fan assembly.

In addition to routine maintenance, motor bearings will require attention if they are not of the sealed type. A separate maintenance document specifically for the motor is supplied and will further detail any lubrication requirements/instructions.

It is essential to ensure that all fixings on the fan assembly are secure. When examining and checking the security of fixings during routine maintenance (see Table 1), those fixings that have locking devices fitted or are painted over, need not be disturbed if they can be seen to be secure. Any locking devices that are disturbed during maintenance must be discarded and replaced with new identical devices. Thread forming screws must have locking compound applied when being reused. Those fixings that have no locking devices fitted and are not painted over, should be checked at 95% of their original setting to ensure no unnecessary disturbance of the fixing. Torque settings for the assembly sequence of the terminal block fixings can be found at the back of this manual. If in doubt about the torque of a particular fixing, contact Woods Air Movement for advice.

After any maintenance, ensure that no loose articles are present in the vicinity of the fan, all safety guards, chains or steel ropes, etc. are properly secured into their original location, and that any temporary device used to stop the fan blades windmilling has been removed.

Routine Maintenance Schedule	Every 6	Every 12	Comments
	Months	Months	
1. Examine the airways into the fan guards (if fitted).	✓		Check fan assemble wiring.
2. Examine motor cooling fins.	✓		Remove any material / dirt build-up between the motor fins.
3. Examine impeller for dirt build-up and for any physical damage.	✓		Remove any build-up of dirt. Ensure impeller is secure. Replace impeller if it is damaged..
4. Examine condition of safety guards (if fitted) and their fixings	✓		Clean safety guards. Replace them if there are any signs of damage.
5. Check operation of anti-condensation heaters (if fitted).	✓		Switch off the power to the motor. Check that the anti-condensation heater is energised (drawing current).
6. Examine the clearance between the fan impeller blade tips and the fan duct. Check the angle, and the security of the impeller blades.		✓	Ensure that the gap between the impeller blade ends and the fan ducts is even and adequate. If in doubt about the gap contact Woods Air Movement for advice. Ensure that the impeller blade is secure. The blade angle must not be changed before contacting Woods Air Movement for advice.
7. Check torque of fan-to-support fixings.		✓	It is essential to confirm that all fixings are properly fitted, are tight, and are fully driven home. If in doubt about the torque of a fixing contact Woods Air Movement for advice.
8. Examine motor, fan and ancillary equipment fixings.		✓	It is essential to confirm that all fixings are properly fitted, are tight, and are fully driven home. If in doubt about the torque of a fixing contact Woods Air Movement Limited for advice.
9. Check movement of vibration isolators (if fitted).		✓	Check freedom of movement. Tighten fixings if necessary.
10. Check motor voltage and current consumption.		✓	Ensure voltage and full load current are as specified on the motor nameplate.
11. Inspect paintwork/galvanising.		✓	Treat any areas of damage with suitable anti-corrosion paint.
12. Crease motor bearings.		✓	Check requirement in accordance with separate motor maintenance document.
13. Check fan assemble wiring.		✓	Check security, and condition, of all wiring (including the earth).

7. INFREQUENT USE

If the fan assembly is used less frequently than once a month, or is designed for emergency-use only, the following additional maintenance procedures must be carried out, and a record kept:

- The resistance of the motor windings to earth should be measured (at 500V d.c) each month. If the reading is less than ten megohms (10 MΩ) the motor should be dried in a warm airflow (typically 40 °C) and re-checked before running the motor.
- The fan should be operated for at least two hours each month to ensure correct lubricant conditions in the bearings.
- The 'emergency-use' system (if applicable) should be run continuously for a minimum of fifteen minutes each month to ensure that the emergency use control system overrides all other controls and switches (see Section 5.5)

8. OVERHAUL / EXTENDED MAINTENANCE

The procedures detailed in this document are designed to keep the fan assembly safe, operational and fault-free, however, in the longer term the fan will require additional servicing that may include a complete overhaul, motor replacement, motor rewinding, spare parts, refurbishment, etc. Information on all aspects of overhaul/extended maintenance is available from Woods Air Movement Service Centre.

It is recommended that the motor shaft seals and bearings are replaced after 20,000 hours or 5 years of normal operation whichever comes sooner. In addition, the motor should be rewound to its original specification after 40,000 hours of normal operation to ensure that adequate insulation life is available should the fan be required for emergency operation. After overhaul/extended maintenance the fan assembly must be safely and correctly installed back into its original position in accordance with this document. The fan should then be checked for smooth and vibration-free running and the current consumption checked to ensure it is within the full load current specified on the fan nameplate.

9. FAULT-FINDING

Fault-finding must be carried out on the fan assembly by appropriately qualified personnel using the correct tools and equipment.

9.1 ELECTRICAL

- Check that the electrical connections to the unit are secure and are in accordance with the wiring connection diagram.
- Check that the voltage applied to the unit is as specified on the motor nameplate and that it is balanced.
- Connect an ammeter in line with each phase (one phase in the case of single-phase motors) of the motor in turn and check that the current consumption is within the full load current specified on the motor nameplate.
- Check that the supply voltage at the fan terminals is as expected and is balanced.
- Measure each motor winding to earth and between each winding using a 500V d.c insulation tester. If the reading is less than ten megohms the reason is liable to be dampness in the motor. To dry the motor place it in a warm (typically 40 degrees centigrade) dry air stream and regularly monitor the motor until the insulation reading is restored to ten megohms or greater. If the reading remains less than ten megohms a breakdown in the motor winding insulation could be the reason, and a motor rewind/overhaul may be necessary.
- Ensure that there is no smell of burnt insulation in the vicinity of the motor.

9.2 MECHANICAL

- Check that there are no obstructions to the motor shaft or impeller blades, that the blades are clean, and that there are no loose components, items or debris in the vicinity.
- Rotate the motor shaft by hand. Investigate any grinding noises, internal chaffing, rubbing or stiffness. If any of these defects are observed, this may indicate that bearings require lubrication or replacement.
- Ensure that all fixings are secure and tightened to the correct torque values.

10. DISPOSAL

Metal components of the fan/motor should be segregated and separately recycled. The following items of material should be safely disposed of in accordance with local health and safety regulations:

- electrical lead coverings,
- motor winding insulation materials,
- bearing lubricant,
- motor/fan terminal block,
- paintwork,
- plastic parts,
- packing materials,
- silencer infill (Note that a face mask and gloves must be worn when handling the infill. If the infill is particularly dry or is damaged it should be damped down before disposal).

11. CONNECTION DIAGRAMS

3 PHASE
TWO SPEED TAPPED

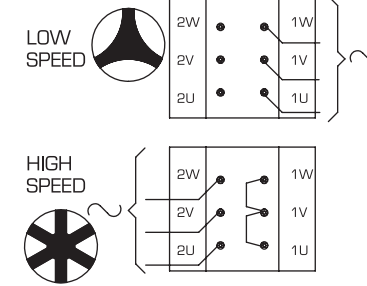

WARNING CONTROL GEAR FOR THIS POLE MOTOR MUST BE SUITED TO THE TAPPED WINDING (DAHLANDER OR P.A.M) THAT IS INCORPORATED. IF IN DOUBT CHECK BEFORE SWITCHING ON.
 HH ANTI CONDENSATION HEATERS } OTHER CIRCUITS IF FITTED
 KK OVERHEAT CUTOUT (MAX AMPS 2.5)
 SS THERMISTOR (OPERATING RESISTANCE 3K Ω).

3 Phase, Two Speed Motor, Pillar Block Terminals

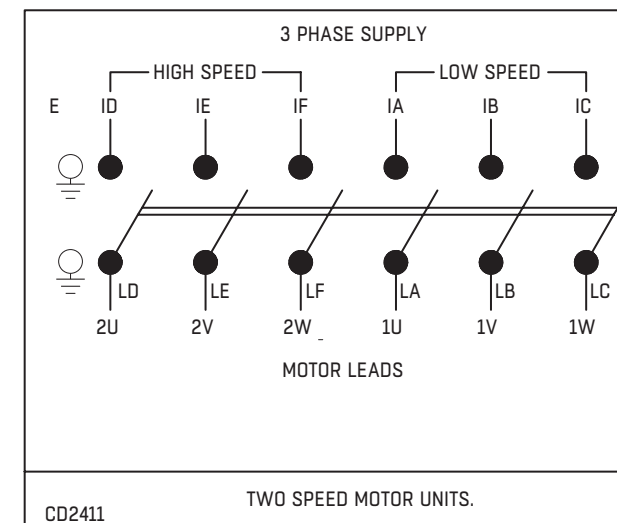

3 Phase Motor with Isolator Fitted for 300°C

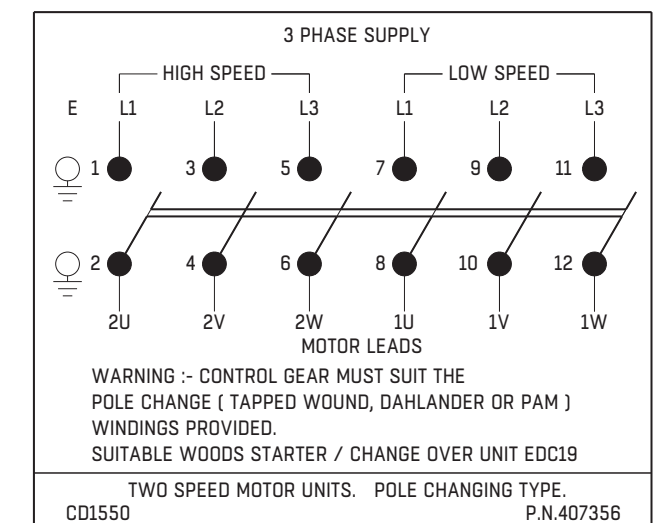
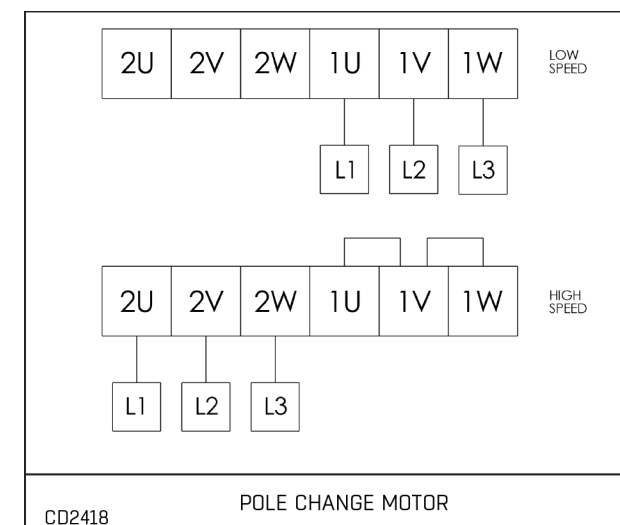

3 Phase Motor with Isolator Fitted for ambient temperature & 200°C Δ

12. TERMINAL BOX CONNECTION ASSEMBLY

IT IS ESSENTIAL THAT NO LOCKWASHERS OR NUTS ARE PLACED BETWEEN THE MOTOR LEAD EYELET, CONNECTING LINK OR CUSTOMERS SUPPLY LEAD EYELET (WHEN FITTED).

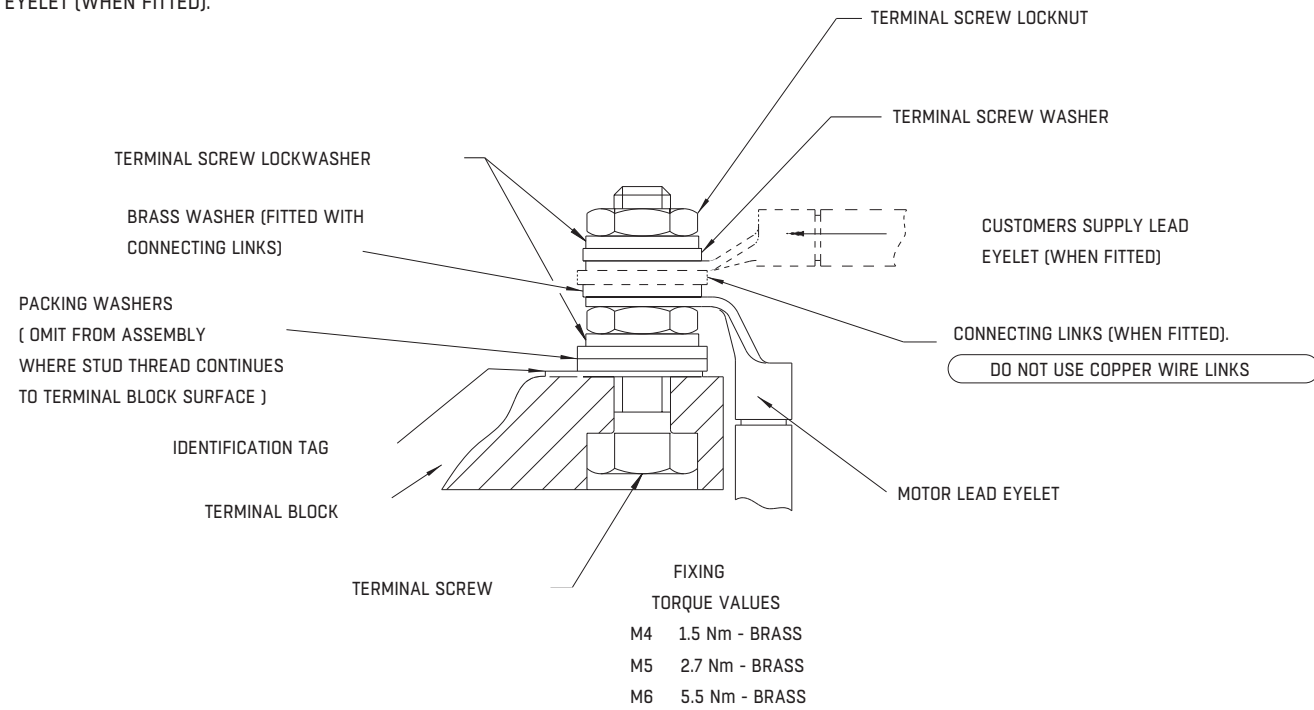

13. INSTALLATION & MAINTENANCE METHODS

Installation method for both Slim-line and Low Profile car park fans

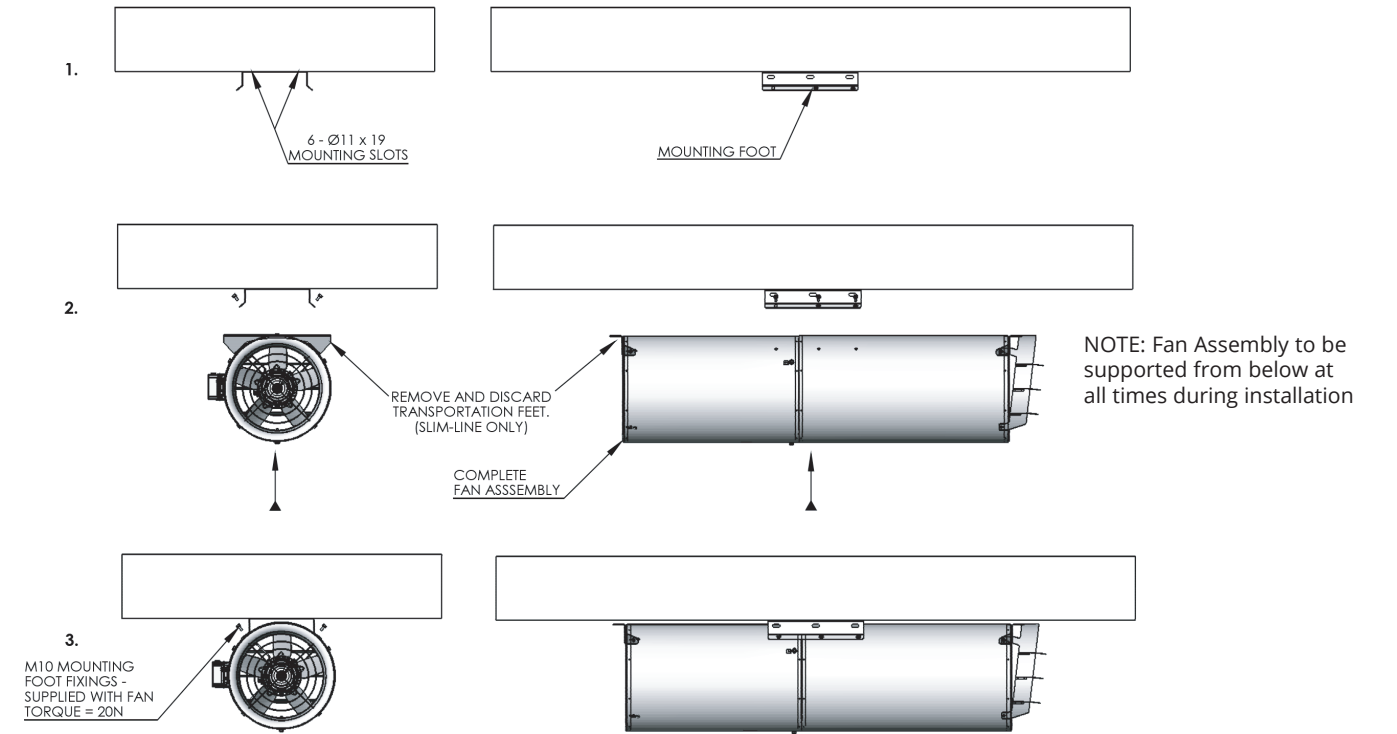

Maintenance method for both Slim-line and Low Profile car park fans

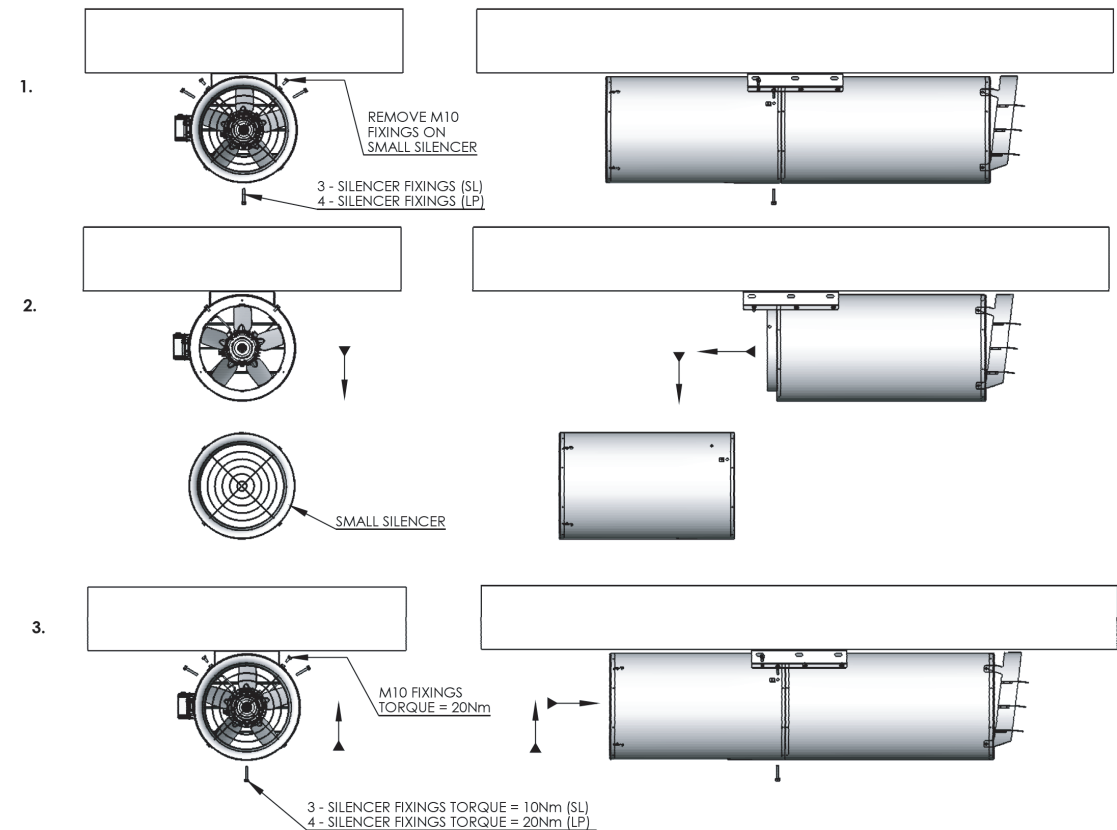



EC Declaration of Conformity

Herewith we declare that the air movement equipment designated below, on the basis of its design and construction, in the form brought on to the market by us, is in accordance with the relevant health and safety requirements of the **EC Council directives on Machinery and Electromagnetic Compatibility and also ecodesign requirements for energy-related products.** If alterations are made to the machinery without prior consultations with us, this declaration becomes invalid. We further declare that the equipment identified below may be intended to be assembled with other equipment/machines to constitute machinery, which shall not be put into service until the assembled machinery has been declared in conformity with the provisions of these EC Council directives.

Designation of equipment: Jet Thrust Fans
Series / type: Machinery Directive (2006/42/EC), Electromagnetic Compatibility Directive (2014/30/EU) where applicable (1) Energy-related products Directive (2009/125/EC) relevant implementing measures: REGULATION (EU) No 327/2011, REGULATION (EU) No 1253/2014, where appropriate
Relevant EC Council directives: EN ISO 12100:2010, EN 60204-1:2018, EN ISO 12499:2008, EN ISO 5136:2010, EN ISO 5801:2017, EN ISO 13350:2015, EN IEC 61000-6-2:2019, EN 61000-6-1:2007, EN 61000-6-3:2007/A1:2011, AC:2012, EN 61000-6-4:2007/A1:2011
Applied harmonized standards in particular (2): BS 848-2:1:2004 (BS ISO 13347-1:2004/A1:2010), BS 848-6:2003 (BS ISO 14695:2003), BS 848-7:2003 (ISO 14694:2003/A1:2011)
Quality Assurance to BS EN ISO 9001:2015
BSI Reg Firm Cert No. FM 155.

Technical file compiled by: Omer Tuzer
FläktGroup Holding GmbH, Bahnhofstr. 65-71, 44623 Herne, Germany

Signed for and on behalf of the manufacturer by:

Stéphane Maravel
Chief Officer Woods

Place: Colchester
Date: 03/10/2023

Position of signatory:

Notes:

- (1) Fläkt Woods fans are driven by AC induction motors, which are inherently compliant if supplied with a truly sinusoidal AC supply. Where the fan motor is supplied via an inverter or other electronic control, verification of its compatibility together with cabling should be sought from the control supplier.
- (2) For a complete list of applied standards and technical specifications see Fläkt Woods documentation.
- (3) Where no relevant harmonised standards exist.

Fläkt Woods Limited 1/a Woods Air Movement

Avial Way
Colchester CO4 5ZD
United Kingdom
Tel: +44 (0) 1206 222555
Email: customerservices.woods@flaktgroup.com
Website: www.woodsairmovement.com



Registered in England no. 233771
Registered office: Avial Way, Colchester, CO4 5ZD, United Kingdom
© Fläkt Woods Limited October 2023

Registered in England no. 233771
Registered office: Avial Way, Colchester, CO4 5ZD, United Kingdom
© Fläkt Woods Limited March 2024

13. FURTHER DOCUMENTATION

EC DECLARATION OF CONFORMITY TO EC MACHINERY DIRECTIVE (98/37/EC)



UKCA Declaration of Conformity

Herewith we declare that the air movement equipment designated below, on the basis of its design and construction, in the form brought on to the market by us, is in accordance with the relevant health and safety requirements of the **UK Parliament Regulations on Product Safety, Electromagnetic Compatibility and Ecodesign for Energy-Related Products.** If alterations are made to the machinery without prior consultations with us, this declaration becomes invalid. We further declare that the equipment identified below may be intended to be assembled with other equipment/machines to constitute machinery, which shall not be put into service until the assembled machinery has been declared in conformity with the provisions of these UK Parliament Regulations.

Designation of equipment: Jet Thrust Fans
Series / type: Fläkt Woods Limited order no:
Relevant UK Regulations: Supply of Machinery (Safety) Regulations 2008, Electromagnetic Compatibility Regulations 2016 where applicable (1) Ecodesign of energy-consuming products relevant implementing measures: REGULATION (EU) No 327/2011, REGULATION (EU) No 1253/2014, where appropriate
Designated standards in particular (2): EN ISO 12100:2010, EN 60204-1:2018, EN ISO 12499:2008, EN ISO 5136:2010, EN ISO 5801:2017, EN ISO 13350:2015, EN IEC 61000-6-2:2019, EN 61000-6-1:2007, EN 61000-6-3:2007/A1:2011, AC:2012, EN 61000-6-4:2007/A1:2011, BS ISO 14695:2003

Basis of self attestation: Quality Assurance to BS EN ISO 9001:2015
BSI Reg Firm Cert No. FM 155.

Technical file compiled by:

Iain Kinghorn
Fläkt Woods Limited, Avial Way, Colchester, CO4 5ZD, United Kingdom

Signed for and on behalf of the manufacturer by:

Stéphane Maravel
Chief Officer Woods

Place: Colchester
Date: 19/03/2024

Position of signatory:

Notes:

- (1) Fläkt Woods fans are driven by AC induction motors which are inherently compliant if supplied with a truly sinusoidal AC supply. Where the fan motor is supplied via an inverter or other electronic control, verification of its compatibility together with cabling should be sought from the control supplier.
- (2) For a complete list of applied standards and technical specifications see Fläkt Woods documentation.

Fläkt Woods Limited 1/a Woods Air Movement

Avial Way
Colchester CO4 5ZD
United Kingdom
Tel: +44 (0) 1206 222555
Email: info.uk@flaktgroup.com
Website: www.flaktgroup.com



Registered in England no. 233771
Registered office: Avial Way, Colchester, CO4 5ZD, United Kingdom
© Fläkt Woods Limited March 2024



Woods Air Movement delivers smart and energy efficient Air Movement and Fire Safety solutions to support every application area. We offer our customers innovative technologies, high quality and outstanding performance supported by more than fifty years of accumulated industry application experience. The widest range of Air Movement and Ventilation products in the market, and strong market presence with over 100 years of experience and manufacturing of products, guarantees that we are always by your side, ready to deliver Excellence in Solutions.

**Contact our friendly sales team today
for more information**

Call: 629 335 9888

Email: sales.us@flaktgroup.com

www.woodsairmovement.com